



LED Work light

Standard Series

The ASD heavy duty portable LED WORK LIGHT has a 360 degree beam angle for full coverage of your work area. It can be plugged into any standard outlet and features a hook and magnet bracket (optional) for secure hanging. Power socket model is linkable, multiple fixtures can be connected in a row, making it perfect for temporary work sites and job site lighting.

The LEDs are protected by a durable steel cage that will withstand any potential drop. This versatile light is suitable for both indoor and outdoor applications. It features a 10 ft. long 3 pin grounded power cord with 6000V surge protection. This light is sturdy and reliable, with an expected life over 200,000 hours.

Catalog number	
Notes	
Type	

FEATURES AND BENEFITS:

- ▶ 6000V Surge Protection
- ▶ Covered and protected LED's
- ▶ 10 ft. long cable
- ▶ Built in power socket (LWL2S model only)
- ▶ 360° Beam Angle
- ▶ Operating temperature of -4°F to 113°F
- ▶ L-70 Life > 200,000 hrs
- ▶ cULus certified
- ▶ 5 Year warranty



ORDERING MATRIX:

Family	Modification	Socket	Watts	Dimmable	CCT
ASD-LWL	1	X	XX	X	50
LED Work light	2	Blank = Without socket S = With Socket	60 = 60 W 100 = 100 W	N = Non-dimmable	5,000 K

LED WORK LIGHT:

Model	Watts	Dimming Compatible	CCT	Lumens	Dimensions (LxWxH)
ASD-LWL1-60N50	60	No	5,000 K	6,951 lm	6 2/3" x 6 2/3" x 13"
ASD-LWL1-100N50	100	No	5,000 K	12,586 lm	6 2/3" x 6 2/3" x 13"
ASD-LWL2S-60N50	60	No	5,000 K	7,175 lm	6 2/3" x 6 2/3" x 13"
ASD-LWL2S-100N50	100	No	5,000 K	12,331 lm	6 2/3" x 6 2/3" x 15"



LED Work light

Standard Series

PRODUCT SPECIFICATIONS:

Construction & Materials				
Housing	Aluminum + PC			
Finish	Silver + Orange			
Cover	Clear			
Weight	ASD-LWL1-60N50	4.03 lbs (1.83 kg)	ASD-LWL2S-60N50	4.01 lbs (1.82 kg)
	ASD-LWL1-100N50	4.47 lbs (2.03 kg)	ASD-LWL2S-100N50	4.78 lbs (2.17 kg)
Environmental System				
Work Environment	ASD-LWL1-60N50	Suitable for Wet Locations, IP65	ASD-LWL2S-60N50	Suitable for Damp Locations, IP44
	ASD-LWL1-100N50		ASD-LWL2S-100N50	
Operating Temperature	-4°F to 113°F (-20°C to 45°C)			
L-70 Life	> 200,000 hrs			
Optical System				
Luminous Flux	ASD-LWL1-60N50	6,951 lm	ASD-LWL2S-60N50	7,175 lm
	ASD-LWL1-100N50	12,586 lm	ASD-LWL2S-100N50	12,331 lm
Color Temperature	5,000 K			
CRI	>80			
Electrical System				
Input Voltage	100-277V AC 50/60 Hz			
Max input current	ASD-LWL1-60N50	0.6 A	ASD-LWL1-100N50	1.0 A
	ASD-LWL2S-60N50		ASD-LWL2S-100N50	
Inrush current	ASD-LWL1-60N50	30 A	ASD-LWL1-100N50	50 A
	ASD-LWL2S-60N50	60 A	ASD-LWL2S-100N50	60 A
Action time (Inrush current)	ASD-LWL1-60N50	350uS	ASD-LWL1-100N50	350uS
	ASD-LWL2S-60N50	387uS	ASD-LWL2S-100N50	425uS
AC input range	min 90 V max 305 V			
Off State Power	0 W			
Power Consumption	ASD-LWL1-60N50	60 W	ASD-LWL1-100N50	100 W
	ASD-LWL2S-60N50		ASD-LWL2S-100N50	
Power Factor	≥ 0.99			
Output voltage	ASD-LWL1-60N50	42-48 V	ASD-LWL1-100N50	36-48 V
	ASD-LWL2S-60N50	35-45 V	ASD-LWL2S-100N50	48-58 V
Max output current	ASD-LWL1-60N50	1,170 mA	ASD-LWL1-100N50	2,000 mA
	ASD-LWL2S-60N50		ASD-LWL2S-100N50	
LED Driver Class	ASD-LWL1-60N50	Class B	ASD-LWL1-100N50	Class B
	ASD-LWL2S-60N50	Class I	ASD-LWL2S-100N50	Class I
Warranty & Certifications				
5-year limited warranty				
cULus certified	E473804			



LED Work light

Standard Series

ASD-LWL1

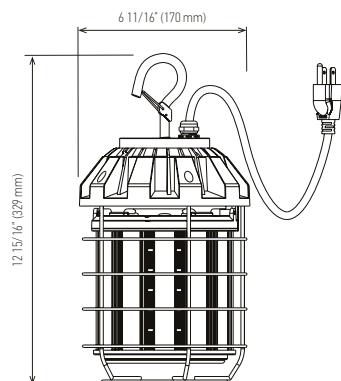

60 W

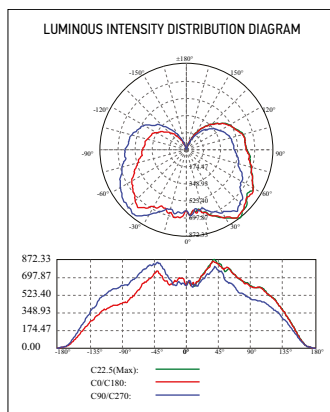

100 W

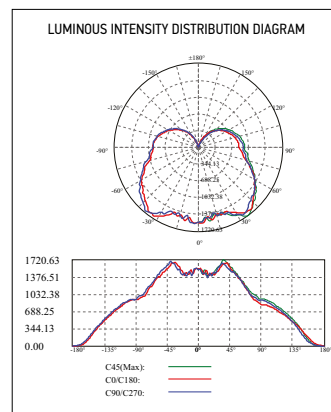

ASD-LWL2S

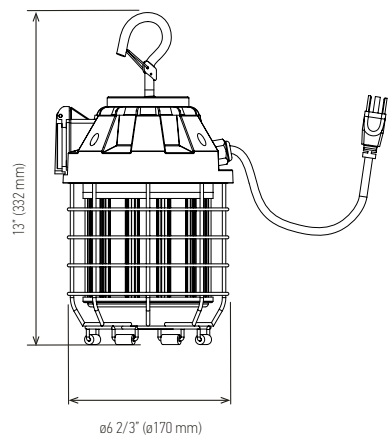

60 W

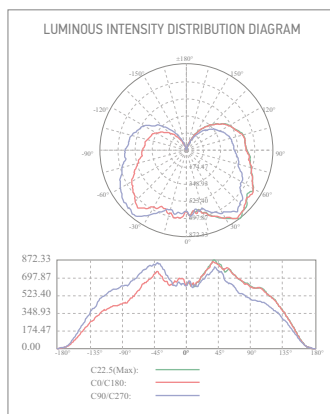

100 W

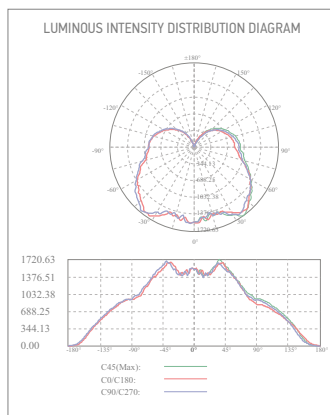

ASD-LWL2S

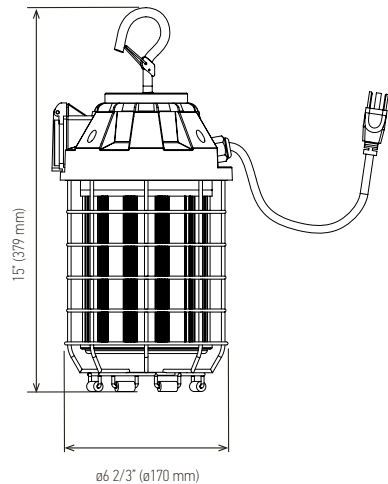



LED Work light

Standard Series

PACKAGE CONTENTS:

Description	Q-ty
LED Work Light Fixture	1
Hook (A)	1
Box	1
Installation Instructions	3

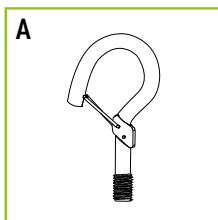

LINKABLE (ASD-LWL2S MODELS)

Multiple fixtures can be connected through built in power sockets.

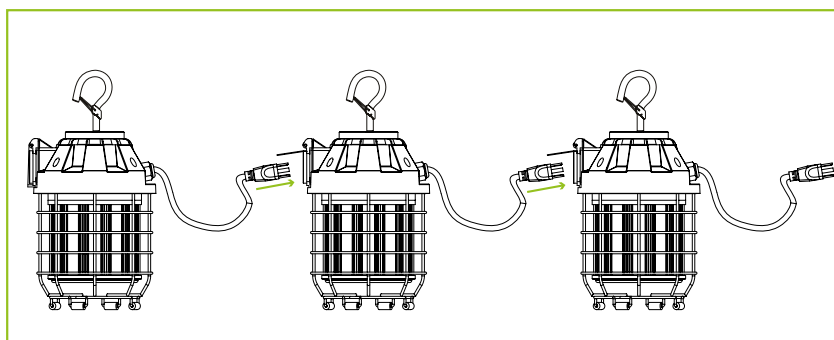

Model	Linkable	
ASD-LWL2S-60N50	Max 16pcs	Max 1,000W
ASD-LWL2S-100N50	Max 10pcs	

⚠ WARNING

RISK OF PERSONAL INJURY – READ and follow all WARNINGS and installation instructions.

Keep or give to the owner for future reference.

Risk of cuts: Wear gloves to prevent cuts or abrasions when removing from carton, handling, installing, and maintaining this product.

Risk of electric shock: This product must be installed in accordance with the applicable installation code by a person familiar with the construction and operation of the product and the hazards involved.

Risk of Fire: Minimum 194°F supply conductors. Consult a qualified electrician to ensure correct branch circuit conductor.

ASD® assumes no responsibility for claims arising out of improper or careless installation or handling of this product.



LED Work light

Standard Series

INSTALLATION GUIDE

IMPORTANT SAFETY INFORMATION:

Please read all the instructions below before installation.

- ▶ Make sure that the supply voltage corresponds to the rated product voltage.
- ▶ The product must be installed by a qualified electrician in accordance with the National Electrical Code and corresponding local codes.
- ▶ If the product is damaged, do not use it.

INSTALLATION STEPS

1. Screw the hook into lamp base.
2. Hang the lamp on the ceiling hook (or any other supporting structure in accordance with the local electric code for temporary lighting). Ensure that the supporting structure is strong enough to bear a min weight of 50lbs.
3. Connect plug and socket. Installation complete.

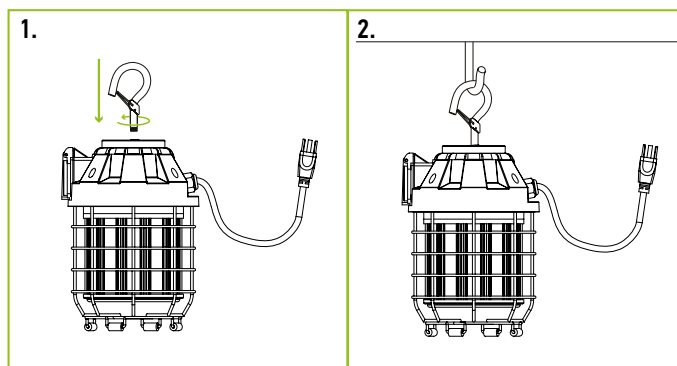

MAGNET BRACKET INSTALLATION

1. Straightly attach bracket to the top of the fixture. Tighten the fasten screw through the bracket.
2. Attach the fixture to the metal surface.
3. Connect plug and socket. Installation complete.

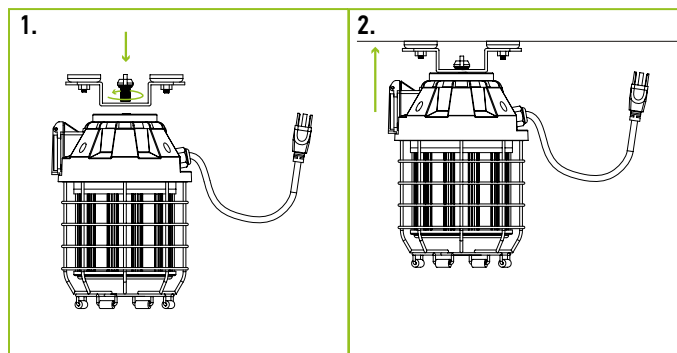

ORDERING INFORMATION

LED WORK LIGHT ORDERING INFORMATION:

Model	Watts	CCT	UPC	GTIN-14	Product Code	Pcs in one Carton	Carton Size	Carton Weight
ASD-LWL1-60N50	60	5,000 K	819201021970	10819201021977	028.0001	4	17.32" x 17.32" x 13.78"	21.4 lbs
ASD-LWL1-100N50	100	5,000 K	819201021987	10819201021984	028.0002	4	17.32" x 17.32" x 13.78"	24 lbs
ASD-LWL2S-60N50	60	5,000 K	819201023776	10819201023773	028.0003	4	17.3" x 17.3" x 12.6"	20.5 lbs
ASD-LWL2S-100N50	100	5,000 K	819201023783	10819201023780	028.0004	4	17.3" x 17.3" x 14.6"	23.6 lbs

MAGNET BRACKET:

Model	Materials	Weight	Dimensions	Pcs in one Carton	Carton Size	Carton Weight
ASD-LWL2-MB	Iron + magnet	0.49 lb (0.22 kg)	5 1/8" x 1 3/7" x 1 1/3"	20	9.6" x 7.9" x 6.1"	12.1 lbs

Model	UPC	GTIN 14	Product Code
ASD-LWL2-MB	819201023790	10819201023797	028.0005