



FIRE RATED LED ROUND RECESSED MINI PANEL

► **DESIGN** - FIRE RATED LED ROUND RECESSED MINI PANEL has a reinforced, heat resistant steel body, and a 2-hour fire resistance rating. This fixture has a J-box, plug & twist connector, and spring-loaded clips, making the installation process quick and easy. The acrylic lens with a 110° beam angle and CRI90+ grants you even light. It is designed to operate on 120V or 120-277V circuits.

► **HEAVY DUTY COMMERCIAL GRADE SPRING CLIPS** - with increased height allow the fixture to be installed in ceilings up to 1-3/4" thick.

► **COLOR SELECTABLE** - You can choose either a 2,700K soft white, 3,000K warm white, 3,500K neutral white, 4,000K cool white, or 5,000K daylight color temperature.

► **INSTALLATION** - This fixture is Air Tight and IC rated so there is no can or any other housing required. When installed in ceilings complying to a fire rated building code (example: type-X gypsum), no additional accessories are needed. It is also Wet Locations rated.

► **ADVANTAGES** - With a lifespan of 50,000 hours, these fixtures are made to last decades under normal operation! ASD provides a 5-year limited warranty along with ETL certification to guarantee top quality products and safety!

Additionally, our fire rated fixtures are tested to comply with UL 263, ASTM E119, and CAN ULC S101.

Catalog number	
Notes	
Type	



Model	Size	Watts	Voltage	Dimmable	Lumens	CCT	Finish	Dimensions (LxH)	Airtight
JFR									
ASD-JFR-4D12AC-WH	4 inch	12W	120 V	TRIAC	up to 840 lm	5CCT (2,700/3,000/3,500/4,000/5,000 K)	White	5' x 2'	Yes
ASD-JFR-6D15AC-WH	6 inch	15W	120 V	TRIAC	up to 1,166 lm	5CCT (2,700/3,000/3,500/4,000/5,000 K)	White	6-7/8' x 2'	Yes
JFRB BAFFLE TRIM									
ASD-JFRB-MV-4D12WH	4 inch	12W	120-277 V	0-10 V	up to 921 lm	5CCT (2,700/3,000/3,500/4,000/5,000 K)	White	5' x 2-3/16'	Yes
ASD-JFRB-MV-6D15WH	6 inch	15W	120-277 V	0-10 V	up to 1,197 lm	5CCT (2,700/3,000/3,500/4,000/5,000 K)	White	6-7/8' x 2-1/4'	Yes

For detailed luminous flux information please refer to Annex 1, page 3.

ANNEX 1

Model	Watts	2,700 K	3,000 K	3,500 K	4,000 K	5,000 K
ASD-JFR-4D12AC-WH	12W	742 lm	785 lm	831 lm	840 lm	807 lm
ASD-JFR-6D15AC-WH	15W	1,086 lm	1,111 lm	1,162 lm	1,166 lm	1,119 lm
ASD-JFRB-MV-4D12WH	12W	835 lm	878 lm	921 lm	911 lm	867 lm
ASD-JFRB-MV-6D15WH	15W	1,098 lm	1,130 lm	1,191 lm	1,197 lm	1,148 lm

For most up-to-date spec sheets please refer to asd-lighting.com



FIRE RATED LED ROUND RECESSED MINI PANEL

PRODUCT SPECIFICATIONS:



Construction & Materials			
Housing	Aluminum, Steel, Metal		
Lens	PC		
Finish	White		
Weight	ASD-JFR-4D12AC-WH	0.9 lbs (0.4 kg)	
	ASD-JFR-6D15AC-WH	1.2 lbs (0.5 kg)	
	ASD-JFRB-MV-4D12WH	1 lbs (0.5 kg)	
	ASD-JFRB-MV-6D15WH	1.5 lbs (0.7 kg)	
Environmental system			
Work environment	Suitable for Wet Locations		
Operating temperature	-4°F to 104°F (-20°C to 40°C)		
L-70 Life	> 50,000 hrs		
Optical system			
Color temperature	5CCT switch (2,700/3,000/3,500/4,000/5,000 K), 5,000 K by default		
CRI	> 90		
Electrical system			
Input voltage	120 V		
	120-277 V		
Max input current	ASD-JFR-4D12AC-WH	0.12 A	
	ASD-JFR-6D15AC-WH	0.15 A	
	ASD-JFRB-MV-4D12WH	0.12 A	
	ASD-JFRB-MV-6D15WH	0.15 A	
	ASD-JFR-4D12AC-WH	5 A (0.5 S)	
Inrush current (Action time)	ASD-JFR-6D15AC-WH	6 A (0.5 S)	
	ASD-JFRB-MV-4D12WH	5 A (0.5 S)	
	ASD-JFRB-MV-6D15WH	6 A (0.5 S)	
	ASD-JFRB-MV-6D15WH	6 A (0.5 S)	
Off state power	0W		
Power consumption	ASD-JFR-4D12AC-WH	12W	
	ASD-JFR-6D15AC-WH	15W	
	ASD-JFRB-MV-4D12WH	12W	
	ASD-JFRB-MV-6D15WH	15W	
Power factor	> 0.9		
Output voltage	36 V		
Max output current	ASD-JFR-4D12AC-WH	0.27 A	
	ASD-JFR-6D15AC-WH	0.34 A	
	ASD-JFRB-MV-4D12WH	0.27 A	
	ASD-JFRB-MV-6D15WH	0.34 A	
Surge protection DM/CM	2.5 kV / 2.5 kV		
Dimming range			
10-100%			
Dimming compatible controls			
Brand	Lutron	Leviton	Cooper
Models	DMD-LE3-D	SFTU-5A3P	IPL06-10Z 6672
	CTCL-153P	PD-6WCL	DSL06 6621
	DVCL-153P	DV-600P	
Regular and voluntary certifications			
5-year limited warranty			
cETLus certified 5003560			

PACKAGE CONTENTS:

Description	Q-ty
Fire rated LED Round Recessed Mini Panel	1
Template for 4 or 6 inch (A)	1
Box	1

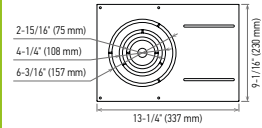
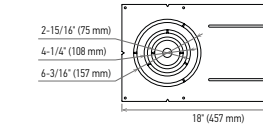
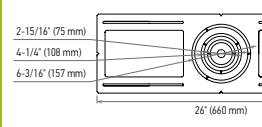
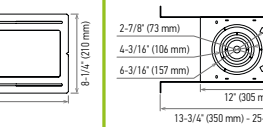

ACCESSORIES (sold separately):

Battery back-up kit 8W BLD-HM08D 15W BLD-HM15D	Smart battery back-up kit 15W ASD-EMA15-NLS
New construction flat mounting plate with asymmetric round holes 3-4-6" ASD-MPLR-346-FA-6PACK	New construction flat mounting plate 18" with asymmetric round holes 3-4-6" ASD-MPLR18-346-FA-6PACK
	
New construction flat mounting plate with symmetric round holes 3-4-6" ASD-MPLR-346-FS-6PACK	New construction mounting plate with round holes and sliding clips 3-4-6" ASD-MPLR-346-SC-6PACK
	
Extension cord 3PIN 10" ASD-EC-10A-6PACK 20" ASD-EC-20A-6PACK	

ACCESSORY COMPATIBILITY LIST:

Models	Accessories							
	Battery back-up kit 8W BLD-HM08D	Battery back-up kit 15W BLD-HM15D	Smart battery back-up kit 15W ASD-EMA15-NLS	New construction flat mounting plate with asymmetric round holes 3-4-6" ASD-MPLR-346-FA-6PACK	New construction flat mounting plate 18" with asymmetric round holes 3-4-6" ASD-MPLR18-346-FA-6PACK	New construction flat mounting plate with symmetric round holes 3-4-6" ASD-MPLR-346-FS-6PACK	New construction mounting plate with round holes and sliding clips 3-4-6" ASD-MPLR-346-SC-6PACK	Extension cord 3PIN ASD-EC-10A-6PACK ASD-EC-20A-6PACK
ASD-JFR-4D12AC-WH		●	●	●	●	●	●	●
ASD-JFR-6D15AC-WH		●	●	●	●	●	●	●
ASD-JFRB-MV-4D12WH	●	●	●	●	●	●	●	●
ASD-JFRB-MV-6D15WH	●	●	●	●	●	●	●	●

For most up-to-date spec sheets please refer to asd-lighting.com



FIRE RATED LED ROUND RECESSED MINI PANEL

BATTERY BACK-UP KIT INFORMATION

BLD-HM08D | **BLD-HM15D** | **ASD-EMA15-NLS** sold separately:

Specifications	model: BLD-HM08D	model: BLD-HM15D	model: ASD-EMA15-NLS
Input voltage	120-347 Vac, 50/60 Hz	120-347 Vac, 50/60 Hz	100-347 Vac, 50/60 Hz
Input current	≤ 100 mA	≤ 100 mA	max 100 mA
Output voltage	≤ 170 Vdc	≤ 175 Vdc	145 Vdc
Output power	8W	15W	15W
Application	< 60W (0-10 V dimmable fixture)	< 100W (0/1-10 V dimmable fixture)	15-120W (0-10 V dimmable fixture)
Ambient temperature	32°F to 122°F (0°C to 50°C)		
Lumens in emergency mode	for 4" model	656 lm	935 lm
	for 6" model	624 lm	1214 lm

INSTALLATION GUIDE

IMPORTANT SAFETY INFORMATION:

Please read all the instructions below before installation.

- ▶ Make sure that the supply voltage corresponds to the rated product voltage.
- ▶ The product must be installed by a qualified electrician in accordance with the National Electrical Code and corresponding local codes.
- ▶ If the product is damaged, do not use it.

⚠ WARNING

RISK OF PERSONAL INJURY – READ and follow all WARNINGS and installation instructions. Keep or give to the owner for future reference.

Risk of cuts: Wear gloves to prevent cuts or abrasions when removing from carton, handling, installing, and maintaining this product.

Risk of electric shock: This product must be installed in accordance with the applicable installation code by a person familiar with the construction and operation of the product and the hazards involved.

Risk of Fire: Minimum 194°F supply conductors. Consult a qualified electrician to ensure correct branch circuit conductor.

ASD® assumes no responsibility for claims arising out of improper or careless installation or handling of this product.

ELECTRICAL SCHEMATIC DIAGRAM:

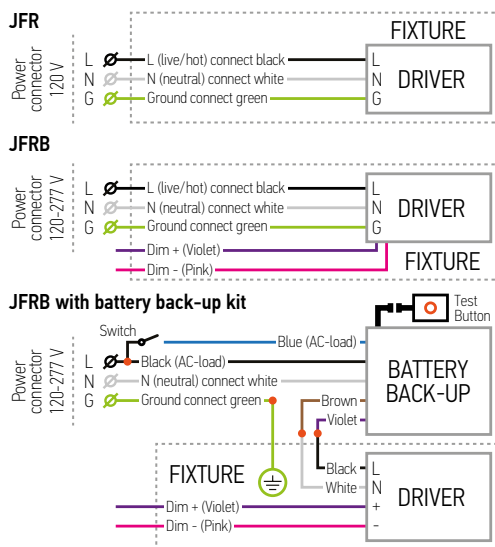

For most up-to-date spec sheets please refer to asd-lighting.com



FIRE RATED LED ROUND RECESSED MINI PANEL

INSTALLATION STEPS:

1. Use template to cut an appropriately sized hole. Disconnect the fixture from the junction box. Choose needed color temperature by adjusting the switch on the junction box or on the cord.
2. Open junction box. Connect the wires: Black to Black, White to White, Green to Green. Secure the connection with quick connector. Close the junction box.
3. Insert the junction box into the cut hole, leaving the connection cable outside. Connect the fixture to the Junction box inserting the cable and securing it with a cap. Push the spring loaded clips upwards and insert the fixture base into the mounting hole. Release the clips, so the fixture fits securely.

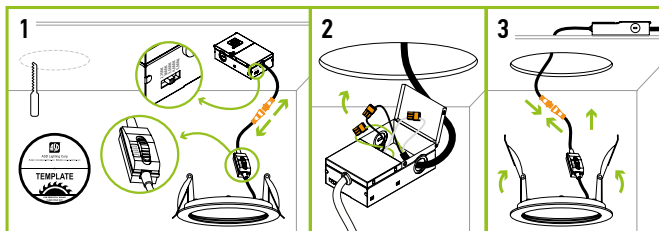

* The fixture is suitable for ceilings up to 1-3/4" thick.

EXTENSION CORD INSTALLATION:

ASD-EC-10A-6PACK **ASD-EC-20A-6PACK**

sold separately:

1. Disconnect the LED Mini Panel cable from the Junction box cable.
2. Connect one end of the Extension Cord to the LED Mini Panel cable, and the other end of the Extension Cord to the Junction box cable.

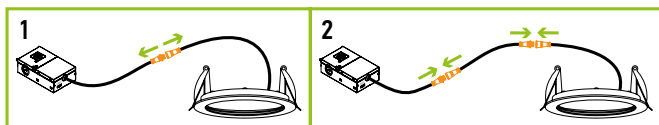

INSTALLATION BATTERY BACK-UP KIT

BLD-HM08D **BLD-HM15D** **ASD-EMA15-NLS**

sold separately:

1. Secure the battery back-up to the ceiling.
2. Connect wires as shown on electrical diagram.
3. Connect test switch and secure it in the hole on surface.

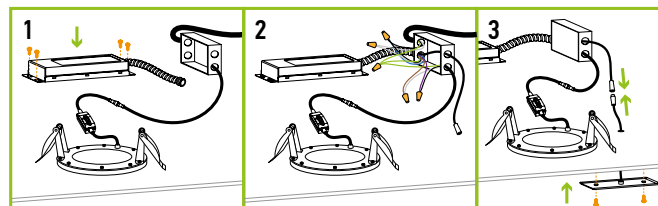

MOUNTING PLATE INSTALLATION

ASD-MPLR-346-FA **ASD-MPLR18-346-FA**

ASD-MPLR-346-FS **ASD-MPLR-346-SC**

sold separately:

1. Remove the metal ring from the mounting plate according to the size of fixture.
2. Place the mounting plate and secure its position with screws on the beams.

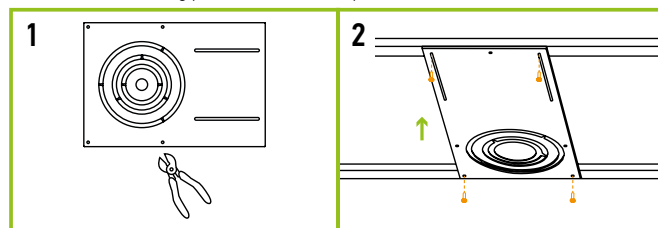

ORDERING INFORMATION

Model	UPC	Pcs. per carton	Carton size	Carton weight	GTIN 14
JFR					
ASD-JFR-4D12AC-WH	810128111485	12	13.6" x 12.4" x 8.1"	13.5 lbs	10810128111482
ASD-JFR-6D15AC-WH	810128111492	12	14.8" x 14.8" x 8.1"	18.1 lbs	10810128111499
JFRB BAFFLE TRIM					
ASD-JFRB-MV-4D12WH	810128115049	6	12.4" x 7.1" x 8.7"	8.9 lbs	10810128115046
ASD-JFRB-MV-6D15WH	810128115056	6	14.8" x 7.7" x 8.1"	12.8 lbs	10810128115053

ACCESSORIES:

Model	Description	UPC	Pcs. per carton	Carton size	Carton weight	GTIN 14
BLD-HM08D	Battery back-up kit 8W	810128111508	10	17.1" x 14.6" x 11"	19.6 lbs	10810128111505
BLD-HM15D	Battery back-up kit 15W	810050734882	10	17.8" x 13.5" x 9.5"	21.1 lbs	10810050734889
ASD-EMA15-NLS	Smart battery back-up kit 15W	810128114356	10	20" x 15.4" x 12"	19.8 lbs	10810128114353
ASD-MPLR-346-FA-6PACK	New construction flat mounting plate with asymmetric round holes 3-4-6"	810050739344	4	14.1" x 10.2" x 3.8"	23.6 lbs	10810050739341
ASD-MPLR18-346-FA-6PACK	New construction flat mounting plate 18" with asymmetric round holes 3-4-6"	810128112826	4	18.9" x 10.2" x 3.8"	32 lbs	10810128112823
ASD-MPLR-346-FS-6PACK	New construction flat mounting plate with symmetric round holes 3-4-6"	810050739351	4	26.9" x 9.5" x 3.8"	26.4 lbs	10810050739358
ASD-MPLR-346-SC-6PACK	New construction mounting plate with round holes and sliding clips 3-4-6"	810050739337	2	17.3" x 11.9" x 13.4"	17 lbs	10810050739334
ASD-EC-10A-6PACK	Extension cord 3PIN 10'	810128110471	10	7.7" x 6.1" x 5.3"	1.8 lbs	10810128110478
ASD-EC-20A-6PACK	Extension cord 3PIN 20'	810128110488	10	7.7" x 6.1" x 7.3"	3.1 lbs	10810128110485

For most up-to-date spec sheets please refer to asd-lighting.com

ASD LIGHTING CORP

E-mail: orders@asd-lighting.com | Web site: www.asd-lighting.com

