



LED LINEAR HIGH BAY WITH Q-BASE

► **DESIGN** - LED LINEAR HIGH BAY WITH Q-BASE has a built-in motion sensor base, allowing you to install microwave or PIR motion sensor. Die-cast aluminum housing with excellent heat dissipation along with an anti-glare PC lens provide many years of use. It is designed to operate on 120-277V circuits with a 0-10V dimmable driver.

► **BATTERY BACK-UP** - The built-in battery back-up provides 90 minutes of power in case of emergency.

► **SURGE PROTECTION** - 6kV protects the fixture from voltage spikes and current surges.

► **COLOR AND POWER SELECTABLE** - You can choose either a 3,500K neutral white, 4,000K cool white or 5,000K daylight color temperature, and change the power with a simple switch.

► **INSTALLATION** - It has three different mounting options: suspended, surface, and pendant. Perfect commercial or industrial solution for warehouses, supermarkets, retail stores, gyms, and many other applications. This fixture is also Damp Locations rated.

► **ADVANTAGES** - With calculated lifespan up to 187,000 hours, these fixtures are made to last decades under normal operation! ASD provides a 5-year limited warranty along with UL and DLC Premium certifications to guarantee top quality products and safety!

Catalog number	
Notes	
Type	



Model	Watts	Sensor base	Voltage	Dimmable	Lumens	CCT	Finish	Dimensions (LxWxH)	Option	
WHB5A										
ASD-WHB5A-100D50	100W	yes	120-277 V	0-10 V	15,230 lm	5,000 K	White	14-3/16" x 9-13/16" x 1-7/8"	-	
ASD-WHB5A-160D50	160W	yes	120-277 V	0-10 V	24,087 lm	5,000 K	White	14-3/16" x 9-13/16" x 1-7/8"	-	
ASD-WHB5A-A160DAC	100/130/160W	yes	120-277 V	0-10 V	21,763/23,258/22,285 lm	3CCT (3,500/4,000/5,000 K)	White	14-3/16" x 9-13/16" x 1-7/8"	-	
ASD-WHB5A-220D50	220W	yes	120-277 V	0-10 V	29,434 lm	5,000 K	White	19-11/16" x 11-13/16" x 2-1/8"	-	
ASD-WHB5A-320D50	320W	yes	120-277 V	0-10 V	43,638 lm	5,000 K	White	39-3/8" x 11-13/16" x 2-1/8"	-	
ASD-WHB5A-A320DAC	220/260/320W	yes	120-277 V	0-10 V	44,761/47,277/46,135 lm	3CCT (3,500/4,000/5,000 K)	White	39-3/8" x 11-13/16" x 2-1/8"	-	
ASD-WHB5A-400D50	400W	yes	120-277 V	0-10 V	53,082 lm	5,000 K	White	39-3/8" x 11-13/16" x 2-1/8"	-	
ASD-WHB5A-500D50	500W	yes	120-277 V	0-10 V	73,306 lm	5,000 K	White	39-3/8" x 11-13/16" x 2-1/8"	-	
ASD-WHB5A-A500DAC	320/400/500W	yes	120-277 V	0-10 V	67,079/69,834/67,311 lm	3CCT (3,500/4,000/5,000 K)	White	39-3/8" x 11-13/16" x 2-1/8"	-	
WHB5A-PRO										
ASD-WHB5A-PRO-100	60/80/100W	yes	120-277 V	0-10 V	15,919/16,402/16,552 lm	3CCT (3,500/4,000/5,000 K)	White	14-3/16" x 9-13/16" x 1-7/8"	-	
ASD-WHB5A-PRO-160	100/130/160W	yes	120-277 V	0-10 V	25,304/26,206/26,276 lm	3CCT (3,500/4,000/5,000 K)	White	19-11/16" x 11-13/16" x 2-1/8"	-	
ASD-WHB5A-PRO-220	130/160/220W	yes	120-277 V	0-10 V	33,988/35,215/35,088 lm	3CCT (3,500/4,000/5,000 K)	White	19-11/16" x 11-13/16" x 2-1/8"	-	
ASD-WHB5A-PRO-320	220/260/320W	yes	120-277 V	0-10 V	49,441/50,958/51,291 lm	3CCT (3,500/4,000/5,000 K)	White	39-3/8" x 11-13/16" x 2-1/8"	-	
ASD-WHB5A-PRO-500	320/400/500W	yes	120-277 V	0-10 V	76,511/80,269/78,972 lm	3CCT (3,500/4,000/5,000 K)	White	39-3/8" x 11-13/16" x 2-1/8"	-	
WHB5A-HV-PRO HIGH VOLTAGE										
ASD-WHB5A-HV-PRO-220	130/160/220W	yes	277-480 V	0-10 V	34,396/36,018/35,470 lm	3CCT (3,500/4,000/5,000 K)	White	19-11/16" x 11-13/16" x 2-1/8"	-	
ASD-WHB5A-HV-PRO-320	220/260/320W	yes	277-480 V	0-10 V	50,461/50,939/50,675 lm	3CCT (3,500/4,000/5,000 K)	White	39-3/8" x 11-13/16" x 2-1/8"	-	
ASD-WHB5A-HV-PRO-500	320/400/500W	yes	277-480 V	0-10 V	76,180/80,049/78,753 lm	3CCT (3,500/4,000/5,000 K)	White	39-3/8" x 11-13/16" x 2-1/8"	-	
WHB5A-EM WITH BATTERY BACK-UP										
ASD-WHB5A-160D50-20EM	160W	yes	120-277 V	0-10 V	21,657 lm	5,000 K	White	14-3/16" x 9-13/16" x 2-11/16"	20W Battery back-up	
ASD-WHB5A-A160DAC-20EM	100/130/160W	yes	120-277 V	0-10 V	21,763/23,258/22,285 lm	3CCT (3,500/4,000/5,000 K)	White	14-3/16" x 9-13/16" x 2-11/16"	20W Battery back-up	
ASD-WHB5A-220D50-20EM	220W	yes	120-277 V	0-10 V	29,434 lm	5,000 K	White	19-11/16" x 11-13/16" x 2-1/8"	20W Battery back-up	
ASD-WHB5A-A220DAC-20EM	130/160/220W	yes	120-277 V	0-10 V	29,845/31,098/30,734 lm	3CCT (3,500/4,000/5,000 K)	White	19-11/16" x 11-13/16" x 2-1/8"	20W Battery back-up	
WHB5A-PRO-EM WITH BATTERY BACK-UP										
ASD-WHB5A-PRO-160-EM	100/130/160W	yes	120-277 V	0-10 V	25,304/26,206/26,276 lm	3CCT (3,500/4,000/5,000 K)	White	19-11/16" x 11-13/16" x 2-1/8"	20W Battery back-up	
ASD-WHB5A-PRO-220-EM	130/160/220W	yes	120-277 V	0-10 V	33,988/35,215/35,088 lm	3CCT (3,500/4,000/5,000 K)	White	19-11/16" x 11-13/16" x 2-1/8"	20W Battery back-up	
HD09VR-MH	Microwave motion sensor								2-1/8" x 2-1/8" x 1-5/16"	-
HD09VR-PH	PIR motion sensor								2-1/8" x 2-1/8" x 1-5/16"	-
HD05R	Remote control for motion sensor								5-1/2" x 2-5/16" x 7/8"	-

For most up-to-date spec sheets please refer to asd-lighting.com



LED LINEAR HIGH BAY WITH Q-BASE

PRODUCT SPECIFICATIONS:

Construction & Materials						
Housing	Die-cast aluminum					
Lens	PC					
Finish	White					
Weight	ASD-WHB5A-100D50	3.9 lbs (1.8 kg)	ASD-WHB5A-A500DAC	13.7 lbs (6.2 kg)	ASD-WHB5A-HV-PRO-500	12.6 lbs (5.7 kg)
	ASD-WHB5A-160D50		ASD-WHB5A-PRO-100	4.2 lbs (1.9 kg)	ASD-WHB5A-160D50-20EM	5.1 lbs (2.3 kg)
	ASD-WHB5A-A160DAC	4 lbs (1.8 kg)	ASD-WHB5A-PRO-160	6.2 lbs (2.8 kg)	ASD-WHB5A-A160DAC-20EM	5.3 lbs (2.4 kg)
	ASD-WHB5A-220D50	6.1 lbs (2.8 kg)	ASD-WHB5A-PRO-220	6.4 lbs (2.9 kg)	ASD-WHB5A-220D50-20EM	7.3 lbs (3.3 kg)
	ASD-WHB5A-320D50	12.3 lbs (5.6 kg)	ASD-WHB5A-PRO-320	12.1 lbs (5.5 kg)	ASD-WHB5A-A220DAC-20EM	7.5 lbs (3.4 kg)
	ASD-WHB5A-A320DAC	12.6 lbs (5.7 kg)	ASD-WHB5A-PRO-500	12.6 lbs (5.7 kg)	ASD-WHB5A-PRO-160-EM	
	ASD-WHB5A-400D50	12.3 lbs (5.6 kg)	ASD-WHB5A-HV-PRO-220	6.4 lbs (2.9 kg)	ASD-WHB5A-PRO-220-EM	7.7 lbs (3.5 kg)
	ASD-WHB5A-500D50	12.5 lbs (5.7 kg)	ASD-WHB5A-HV-PRO-320	12.1 lbs (5.5 kg)		
Environmental system						
Work environment	Suitable for Damp Locations					
Operating temperature	-40°F to 122°F (-40°C to 50°C)					
L-70 Life	for WHB5A and ASD-WHB5A-160D50-20EM models: R > 54,000 hrs; C > 187,000 hrs			for ASD-WHB5A-500D50 model: R > 54,000 hrs; C > 147,000 hrs		
	for PRO, HV-PRO and WHB5A-PRO-EM models: R > 102,000 hrs; C > 167,000 hrs			for DAC and ASD-WHB5A-A160DAC-20EM model: R > 54,000 hrs; C > 182,000 hrs		
ASD-WHB5A-A220DAC-20EM model: R > 48,000 hrs; C > 159,000 hrs						
Optical system						
Luminous flux	ASD-WHB5A-100D50	15,230 lm	ASD-WHB5A-A500DAC	67,311 lm	ASD-WHB5A-HV-PRO-500	76,180/80,049/78,753 lm
	ASD-WHB5A-160D50	24,087 lm	ASD-WHB5A-PRO-100	15,919/16,402/16,552 lm	ASD-WHB5A-160D50-20EM	21,657 lm
	ASD-WHB5A-A160DAC	21,763/23,258/22,285 lm	ASD-WHB5A-PRO-160	25,304/26,206/26,276 lm	ASD-WHB5A-A160DAC-20EM	21,763/23,258/22,285 lm
	ASD-WHB5A-220D50	29,434 lm	ASD-WHB5A-PRO-220	33,988/35,215/35,088 lm	ASD-WHB5A-220D50-20EM	29,434 lm
	ASD-WHB5A-320D50	43,638 lm	ASD-WHB5A-PRO-320	49,441/50,958/51,291 lm	ASD-WHB5A-A220DAC-20EM	29,845/31,098/30,734 lm
	ASD-WHB5A-A320DAC	44,761/47,277/46,135 lm	ASD-WHB5A-PRO-500	76,511/80,269/76,972 lm	ASD-WHB5A-PRO-160-EM	25,304/26,206/26,276 lm
	ASD-WHB5A-400D50	53,082 lm	ASD-WHB5A-HV-PRO-220	34,396/36,018/35,470 lm	ASD-WHB5A-PRO-220-EM	33,988/35,215/35,088 lm
	ASD-WHB5A-500D50	67,079/69,834/67,311 lm	ASD-WHB5A-HV-PRO-320	50,461/50,939/50,675 lm		
Color temperature	5,000 K 3CCT switch (3,500/4,000/5,000 K), 5,000 K by default					
CRI	> 80					
Electrical system						
Input voltage	Regular voltage: 120-277 V					
	High voltage: 277-480 V					
Max input current	ASD-WHB5A-100D50	0.91 A	ASD-WHB5A-A500DAC	5.1 A	ASD-WHB5A-HV-PRO-500	1.2 A
	ASD-WHB5A-160D50	1.46 A	ASD-WHB5A-PRO-100	1.3 A	ASD-WHB5A-160D50-20EM	1.6 A
	ASD-WHB5A-A160DAC	1.6 A	ASD-WHB5A-PRO-160	2 A	ASD-WHB5A-A160DAC-20EM	
	ASD-WHB5A-220D50	2.02 A	ASD-WHB5A-PRO-220	2.6 A	ASD-WHB5A-220D50-20EM	2.3 A
	ASD-WHB5A-320D50	2.93 A	ASD-WHB5A-PRO-320	3 A	ASD-WHB5A-A220DAC-20EM	2.02 A
	ASD-WHB5A-A320DAC		ASD-WHB5A-PRO-500	4 A	ASD-WHB5A-PRO-160-EM	2 A
	ASD-WHB5A-400D50	3.67 A	ASD-WHB5A-HV-PRO-220	1.1 A	ASD-WHB5A-PRO-220-EM	2.6 A
	ASD-WHB5A-500D50	5.1 A	ASD-WHB5A-HV-PRO-320	1.8 A		
Inrush current (Action time)	for WHB5A: 60 A (1.5 S)		for WHB5A-PRO and EM models: 80 A (0.35 S)		for HV models: 45 A (0.2 S)	
Off state power	0W					
Power consumption	ASD-WHB5A-100D50	110W	ASD-WHB5A-A500DAC	320/400/500W	ASD-WHB5A-HV-PRO-500	320/400/500W
	ASD-WHB5A-160D50	160W	ASD-WHB5A-PRO-100	60/80/100W	ASD-WHB5A-160D50-20EM	160W
	ASD-WHB5A-A160DAC	100/130/160W	ASD-WHB5A-PRO-160	100/130/160W	ASD-WHB5A-A160DAC-20EM	100/130/160W
	ASD-WHB5A-220D50	220W	ASD-WHB5A-PRO-220	130/160/220W	ASD-WHB5A-220D50-20EM	220W
	ASD-WHB5A-320D50	320W	ASD-WHB5A-PRO-320	220/260/320W	ASD-WHB5A-A220DAC-20EM	130/160/220W
	ASD-WHB5A-A320DAC	220/260/320W	ASD-WHB5A-PRO-500	320/400/500W	ASD-WHB5A-PRO-160-EM	100/130/160W
	ASD-WHB5A-400D50	400W	ASD-WHB5A-HV-PRO-220	130/160/220W	ASD-WHB5A-PRO-220-EM	130/160/220W
	ASD-WHB5A-500D50	500W	ASD-WHB5A-HV-PRO-320	220/260/320W		
Power factor	> 0.9					
Output voltage	260 V					
	for PRO models: 180-260 V for ASD-WHB5A-100D50, ASD-WHB5A-160D50 and ASD-WHB5A-160D50-20EM models: 130 V					
Max output current	ASD-WHB5A-100D50	0.9 A	ASD-WHB5A-A500DAC		ASD-WHB5A-HV-PRO-500	0.196 A
	ASD-WHB5A-160D50	1.25 A	ASD-WHB5A-PRO-100	0.39 A	ASD-WHB5A-160D50-20EM	1.28 A
	ASD-WHB5A-A160DAC		ASD-WHB5A-PRO-160	0.63 A	ASD-WHB5A-A160DAC-20EM	1.25 A
	ASD-WHB5A-220D50	0.9 A	ASD-WHB5A-PRO-220	0.86 A	ASD-WHB5A-220D50-20EM	0.88 A
	ASD-WHB5A-320D50	1.5 A	ASD-WHB5A-PRO-320	1.25 A	ASD-WHB5A-A220DAC-20EM	0.9 A
	ASD-WHB5A-A320DAC		ASD-WHB5A-PRO-500	0.196 A	ASD-WHB5A-PRO-160-EM	0.63 A
	ASD-WHB5A-400D50	0.9 A	ASD-WHB5A-HV-PRO-220	0.86 A	ASD-WHB5A-PRO-220-EM	0.86 A
	ASD-WHB5A-500D50	2 A	ASD-WHB5A-HV-PRO-320	1.25 A		
Surge protection DM/CM	6 kV / 6 kV for ASD-WHB5A-100D50, ASD-WHB5A-160D50 and ASD-WHB5A-160D50-20EM models: 4 kV / 6 kV					

For most up-to-date spec sheets please refer to asd-lighting.com



LED LINEAR HIGH BAY WITH Q-BASE







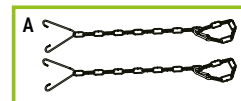

Dimming compatible controls			
Brand	Lutron		Leviton
Models	DVSTV	DVTV	DS710
Regular and voluntary certifications			
5-year limited warranty			
DesignLights Consortium (DLC) listed (Classification: Premium)			
Main: Indoor luminaires; General application: High-bay;			
Primary use: High-bay luminaires for commercial and industrial buildings			
UL certified E473804			

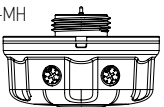
PACKAGE CONTENTS:

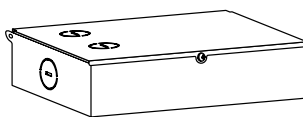
Description	Q-ty
LED Linear High Bay with Q-Base	1
Hanging kit: V hook, chain 3.2ft (A)	1
Box	1

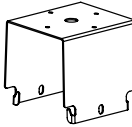

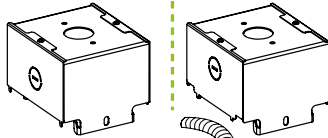
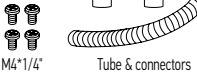
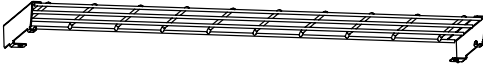
ACCESSORIES (sold separately):

Microwave motion sensor HD09VR-MH 	Remote control for motion sensor HD05R 	Battery back-up kit  20W for 100/160W ASD-EMK20W-WHB5A 20W for 220/320/400/500W ASD-EMK20W-WHB5B 30W for 100/160/220/320/400/500W ASD-EMK30W-WHB5A 	Surface mounting bracket ASD-SMB1-WHB5  	Pendant mount bracket for 100/160/220W ASD-PMB1-WHB5 for 320/400/500W ASD-PMB2-WHB5  
Wire guard for 100/160W ASD-WG14-WHB5 for 220W ASD-WG20-WHB5   				

ACCESSORY COMPATIBILITY LIST:

Models	Accessories									
	Microwave motion sensor HD09VR-MH	PIR motion sensor HD09VR-PH	Battery back-up kit 20W ASD-EMK20W-WHB5A	Battery back-up kit 20W ASD-EMK20W-WHB5B	Battery back-up kit 30W ASD-EMK30W-WHB5A	Surface mount bracket ASD-SMB1-WHB5	Pendant mounting bracket ASD-PMB1-WHB5	Pendant mounting bracket ASD-PMB2-WHB5	Wire guard 14" ASD-WG14-WHB5	Wire guard 20" ASD-WG20-WHB5
ASD-WHB5A-100D50	•	•	•			•	•		•	
ASD-WHB5A-160D50	•	•	•			•	•		•	
ASD-WHB5A-A160DAC	•	•		•	•	•	•		•	
ASD-WHB5A-220D50	•	•		•	•	•	•			•
ASD-WHB5A-320D50	•	•		•	•	•		•		
ASD-WHB5A-A320DAC	•	•		•	•	•		•		
ASD-WHB5A-400D50	•	•		•	•	•		•		
ASD-WHB5A-500D50	•	•		•	•	•		•		
ASD-WHB5A-A500DAC	•	•		•	•	•		•		
ASD-WHB5A-PRO-100	•	•		•	•	•	•		•	
ASD-WHB5A-PRO-160	•	•		•	•	•	•			•
ASD-WHB5A-PRO-220	•	•		•	•	•	•			•
ASD-WHB5A-PRO-320	•	•		•	•	•		•		
ASD-WHB5A-PRO-500	•	•		•	•	•		•		
ASD-WHB5A-HV-PRO-220	•	•		•	•	•	•			•
ASD-WHB5A-HV-PRO-320	•	•		•	•	•		•		
ASD-WHB5A-HV-PRO-500	•	•		•	•	•		•		
ASD-WHB5A-160D50-20EM	•	•		•	•	•	•		•	
ASD-WHB5A-A160DAC-20EM	•	•		•	•	•	•		•	
ASD-WHB5A-220D50-20EM	•	•		•	•	•	•			•
ASD-WHB5A-A220DAC-20EM	•	•		•	•	•	•			•
ASD-WHB5A-PRO-160-EM	•	•		•	•	•	•			•
ASD-WHB5A-PRO-220-EM	•	•		•	•	•	•			•

For most up-to-date spec sheets please refer to asd-lighting.com



LED LINEAR HIGH BAY WITH Q-BASE

MOTION SENSOR INFORMATION

REMOTE CONTROL **HD05R** sold separately:

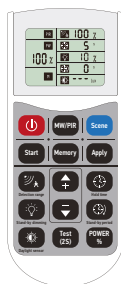

Button	Remarks	Button	Remarks	Button	Remarks
	ON/OFF Turn the sensor ON/OFF.		Apply Applies current scene settings to the fixture.		Hold time The period that light will stay illuminated 100 % after no motion is detected. Use this button and the + - buttons to adjust.
	MW/PIR Select Microwave or PIR sensor.		Detection range Also known as "sensitivity", 100 % means the highest sensitivity and longest distance. Use this button and the + - buttons to adjust.		Stand-by period The period after holdtime, during which the light keeps standby dimming level. Use this button and the + - buttons to adjust.
	Scene Shows current settings saved in remote.		Stand-by dimming After hold time, the light will dim from 100 % to optional standby dimming levels. Use this button and the + - buttons to adjust.		Daylight sensor The preset lux level at which motion will be detected. Use this button and the + - buttons to adjust.
	Start Press this to begin scene setup.		UP The main functional buttons to adjust the factors to desired level. Press + - button to dim light directly in non-detection mode.		Test mode Press this button to test the sensor; it will temporarily change the hold time to 2s. This setting cannot be saved.
	Memory Saves the scene settings.		DOWN		Power The dimming output in detection mode. Use this button and the + - buttons to adjust.

* When any programming is set, icon will blink for 5s and fixture will dim and then resume at 100% meaning the program has been saved.



HD09VR-PH
PIR motion sensor

+



HD05R
remote control
(sold separately)



HD09VR-MH
Microwave motion sensor

+



HD05R
remote control
(sold separately)

HD09VR-MH: Ceiling mounted

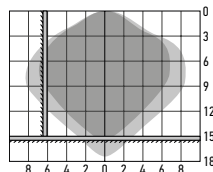

Wall mounted

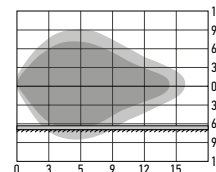

- Highest mounting height is 49.2ft (15m)
 - This figure indicates the maximum distance at the highest mounting height with 100 % sensitivity.
- Well detected area
■ Possibly detected area

Installation precautions:

1. Microwave sensor can be installed in any lamp except one with a full metal shell.
2. The detected surface cannot be shielded by metal objects.
3. Make sure the microwave module is completely exposed.
4. The detection surface of the sensor module should be installed facing the detection area.

Application environment:

1. Suitable for indoor installation to avoid false triggering due to external factors such as rain, wind or tree movement.
2. Shall not be installed in a place with all metal walls or small spaces (such as galvanized-iron roof).
3. Shall be mounted securely, to avoid any false triggers caused by movement of the fixture itself.
4. Shall not be installed next to large operating machines such as a ventilator or ceiling fan, to avoid false triggers caused by machine vibration.

User notes:

1. Microwaves can penetrate walls or glass thinner than 0.8" but will be impaired if thicker than 0.8".
2. The driver voltage shall be stable and float within 10 %.
3. Detection area will be affected by speed of motion, mounting height and movement volume.
4. Conduct testing with adequate ambient lighting for best results.

HD09VR-PH:

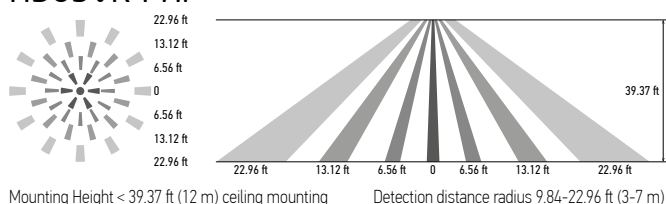

Specifications	Model: HD09VR-PH	Model: HD09VR-MH
Operating voltage	10-15 V	
Operating current	< 15 mA	< 30 mA
Working mode	0-10 V	
Detection area	25 %/50 %/75 %/100 %	
Hold time	Remote control: 5 s/30 s/1 min/3 min/5 min/10 min/20 min/30 min	Built-in switch: 5 s/1 min/5 min/10 min
Daylight threshold	2 lux (0.2 fc)/10 lux (0.9 fc)/30 lux (2.8 fc)/50 lux (4.7 fc)/80 lux (7.4 fc)/120 lux (11.2 fc)/200 lux (18.6 fc)/250 lux (23.2 fc)/300 lux (27.9 fc)/350 lux (32.5 fc)/400 lux (37.2 fc)/disable	
Standby period	0 s/10 s/30 s/1 min/5 min/10 min/30 min/60 min/+ ∞	
Standby dimming level	Remote control: 10 %/20 %/30 %/50 %	Built-in switch: 0 %/10 %/30 %/50 %
Operating temperature	- 4°F to 140°F (-20°C to 60°C)	- 40°F to 158°F (-40°C to 70°C)
Mounting height	≤ 39 ft (12 m)	max 49.2 ft (15 m)
Detection range	≥ 9 ft (3 m)	
Operating frequency	-	5.8 GHz ± 75 GHz
Transmitting power	-	< 0.3 mW
IP rating	IP65	

DEFAULT SETTING:

Specifications	
Detection area	100 %
Hold time	20 min
Daylight threshold	Disable
Stand-by period	0 s
Stand-by dimming level	10 %

⚠ RF interference may affect the operation of this sensor.

For most up-to-date spec sheets please refer to asd-lighting.com



LED LINEAR HIGH BAY WITH Q-BASE

WITH DUSK/DAWN FUNCTION:

1. With insufficient ambient brightness, sensor turns on light and keeps it at standby dimming level even if there is no motion or presence.
2. When sensor detects motion or presence it will bring the light level up to 100%.
3. After motion is no longer detected, fixture remains at 100% for hold time.
4. After pre-set hold time period it will dim to standby dimming level again and always keep it.
5. With sufficient ambient brightness, sensor will turn OFF light automatically.

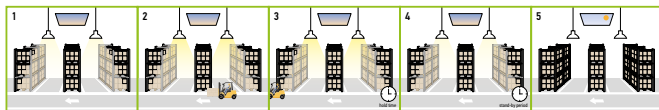

WITH DAYLIGHT DISABLED:

1. Sensor turns ON light when motion is detected.
2. Light will stay on after detecting motion for the desired hold time.
3. Sensor dims light to standby dimming level after hold time if there is still no motion.
4. Sensor turns OFF light after standby period.

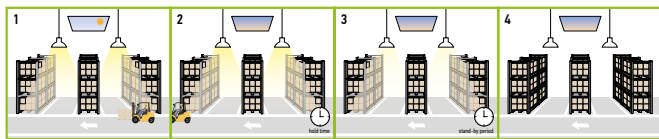

WITH DAYLIGHT THRESHOLD:

1. With sufficient daylight, the light remains OFF even after motion is detected.
2. With insufficient daylight, the sensor turns light ON when motion is detected.
3. After there's no motion detected, the sensor keeps light ON 100% for holdtime.
4. After holdtime, sensor dims light to standby dimming level for standby period. If the standby period has been set as 0s, sensor turns light OFF automatically after holdtime.
5. The sensor turns OFF light automatically after the standby period when there's no motion detected.

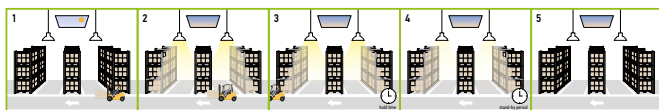

DAYLIGHT HARVESTING:

1. When ambient brightness is lower than preset lux level, sensor will turn on light automatically and keep dimming according to the change of the ambient brightness. As it gets darker outside the fixtures will brighten, and as it gets brighter outside the fixtures will dim down.
2. When the ambient brightness exceeds the preset lux level, the light will turn OFF.

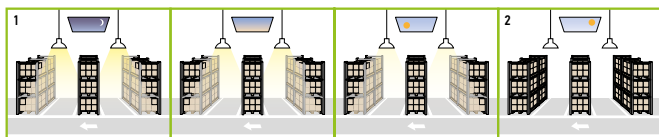

Only for HD09VR-MH and HD09VR-PH models.

To avoid blocking the microwave emission, the microwave sensor can not be covered with metal materials, be sprayed with a coating of metal components, or have attached metal material or stickers etc.

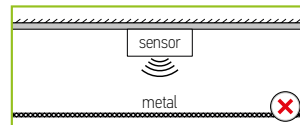

The distance between the antenna and the glass (dielectric material) should be no less than 0.4ft when the sensor is within the glass lampshade. Otherwise, the microwave motion sensor will not penetrate the glass easily.

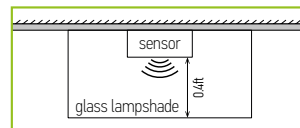

Avoid placing the sensor inside a metal chamber, this may cause a mis-trigger.

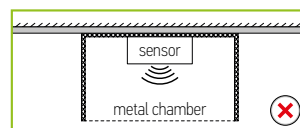

The sensor should not be placed in a small confined space. To avoid increasing the sensor detection range or abnormal operation, the sensor should be kept away from large areas of metal and glass reflectors (separation distance at least 3.3ft). Reduce the detection area setting.

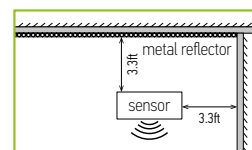

To avoid affecting the microwave signal transmission, the microwave antenna should be higher than the surrounding metal surface.

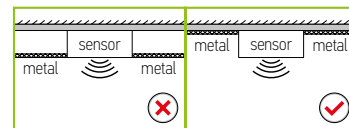

Any vibration or movement may trigger the sensor. Ensure the sensor is far from any constant movement.

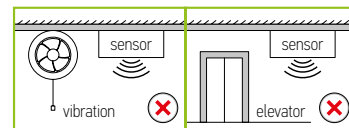

When multiple sensors are installed side-by-side in the same direction, the distance between each sensor should be at least 3.3ft (the warehouse sensors at least 9.8ft) to avoid mutual interference.

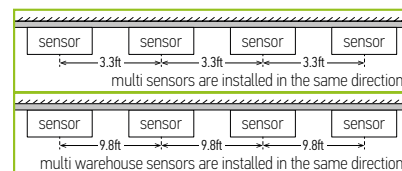

DAYLIGHT HARVESTING SETTING:

1. Adjust "daylight" value higher than 50lux.
2. Preset "standby period" 0S
3. Press MW/PIR icons are both blinking on LCD screen, daylight harvesting function enabled. (With BLE version, press DH button, daylight harvesting function enabled).

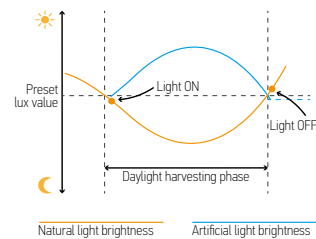

For most up-to-date spec sheets please refer to asd-lighting.com





LED LINEAR HIGH BAY WITH Q-BASE

BUILT-IN BATTERY BACK-UP INFORMATION

Model	Battery watts	Lumens in emergency mode	Battery capacity	Emergency mode	Charging time
ASD-WHB5A-160D50-20EM	20W	3,189 lm	3,200 mA * 8	≥ 90 minutes	≥ 24 hours
ASD-WHB5A-A160DAC-20EM	20W	3,189 lm	3,200 mA * 8	≥ 90 minutes	≥ 24 hours
ASD-WHB5A-220D50-20EM	20W	3,207 lm	3,200 mA * 8	≥ 90 minutes	≥ 24 hours
ASD-WHB5A-A220DAC-20EM	20W	3,207 lm	3,200 mA * 8	≥ 90 minutes	≥ 24 hours
ASD-WHB5A-PRO-160-EM	20W	3,200 lm	3,200 mA * 8	≥ 90 minutes	≥ 24 hours
ASD-WHB5A-PRO-220-EM	20W	3,200 lm	3,200 mA * 8	≥ 90 minutes	≥ 24 hours

Specifications	
Input voltage	100-277 V 50/60 Hz
Warranty	5 years
Indicator light	Illuminated test switch, indicator light
Battery type	Li-ion
Battery charging current	250 mA
Charging time	≥ 24 hours

STANDARD OPERATION DISPLAY STATUS:

Charging	
Emergency mode	 Flash slowly
Test failure	 Flash quickly

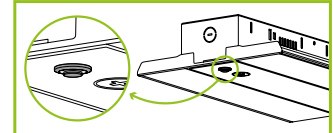

BACK-UP BATTERY KIT INFORMATION

ASD-EMK20W-WHB5A ASD-EMK20W-WHB5B

ASD-EMK30W-WHB5A sold separately:

ASD-EMK20W-WHB5A, ASD-EMK20W-WHB5B, ASD-EMK30W-WHB5A self-check emergency battery back-up kit offers a dependable solution for virtually every LED Linear High Bay lighting application, with options tailored for both new fixture constructions and field installation applications. For more information please visit our website <https://www.asd-lighting.com/>

- ▶ Standard UL924 certification
- ▶ Battery Protection
- ▶ Over charge protection
- ▶ Over discharge protection
- ▶ Short circuit protection
- ▶ Battery Status Indicator Light
- ▶ Intelligent Emergency Detection Function
- ▶ 5 year warranty
- ▶ Emergency time : 90 minutes

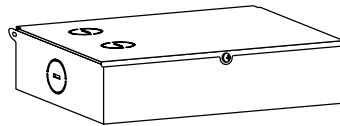

Emergency operation:

AC Operation, red indicator light will stay on. Emergency Operation, indicator light will flash slowly (light on for 2 seconds, light off for 2 seconds). In a failure, the indicator light will flash quickly (light on for 0.2 seconds, light off for 0.2 seconds).

Specifications	Model: ASD-EMK20W-WHB5A	Model: ASD-EMK20W-WHB5B	Model: ASD-EMK30W-WHB5A
Input voltage	120-277 V 50/60 Hz		
AC input current	100 mA max.		
AC input power rating	7.0W max.		
Output voltage	81 - 155 Vdc	156 - 230 Vdc	156 - 230 Vdc
Output power	20W	20W	30W
Lumens	3,189 lm	3,189 lm	4,783 lm
Emergency time	≥ 1.5 hours		
Warranty	5 years		
Indicator light	Illuminated test switch, red, indicator light		
Battery type	Li-ion		
Charging time	≥ 24 hours		
Temperature rating (Ambient)	-22°F to 122°F (-30°C to 50°C)		
Dimensions	9-5/8" x 4-5/8" x 1-7/8" (244 mm x 117 mm x 48 mm)		
Weight	0.9 lbs (0.41 kg)		

CAUTION:

- ▶ Before doing high-voltage insulation test, must remove the battery pack first and make sure there is not any contact between the battery pack and the led drivers.
- ▶ After test, disconnect the unit connector of the battery pack first before shipping and storing.
- ▶ During storage, the battery pack will need 24 hours of charge every 3 months.

For most up-to-date spec sheets please refer to asd-lighting.com



LED LINEAR HIGH BAY WITH Q-BASE

BATTERY BACK-UP KIT

ASD-EMK20W-WHB5A

ASD-EMK20W-WHB5B

ASD-EMK30W-WHB5A

sold separately:

1. Unscrew and open Battery back-up kit.
2. Remove one knockout on the driver box on the top of the fixture and one on the side. Attach battery back-up kit to the driver box of the fixture with 4 screws.
3. Unscrew 4 screws and open driver box of the fixture. Install battery back-up button to the side knockout of the fixture and secure it with washer (included). Then pull the button wire into the battery back-up kit and plug it to the battery controller.
4. Connect battery back-up kit to the fixture by:
 - a. Pull the Red wire (DRIVER +) from battery back-up into the fixture and connect it to the Red wire (Driver output +);
 - b. Pull the Black wire (LED- / DRIVER -) from battery back-up into the fixture and connect it with the Black wire (Driver output -), Led1 (input -) and Led2 (-) using one connector (included);
 - c. Pull the White wire (LED +) from battery back-up into the fixture and connect it with the Led1 (+) and Led2 (+) using one connector (included);
5. Pull the White(N), Black (L), Green(G), Pink (Dim-) and Violet (Dim+) wires from the fixture into the battery back-up kit and connect them with the wires of battery back-up and external power source: Black with Black, White with White, Green with Green, according to the wiring schematic. Use white extension wire (included) if needed. Use pink (Dim-) and violet (Dim+) dimming wires if needed to connect to the dimmer.
6. Attach fixture driver box cover with battery back-up kit to the fixture and secure it with screws.

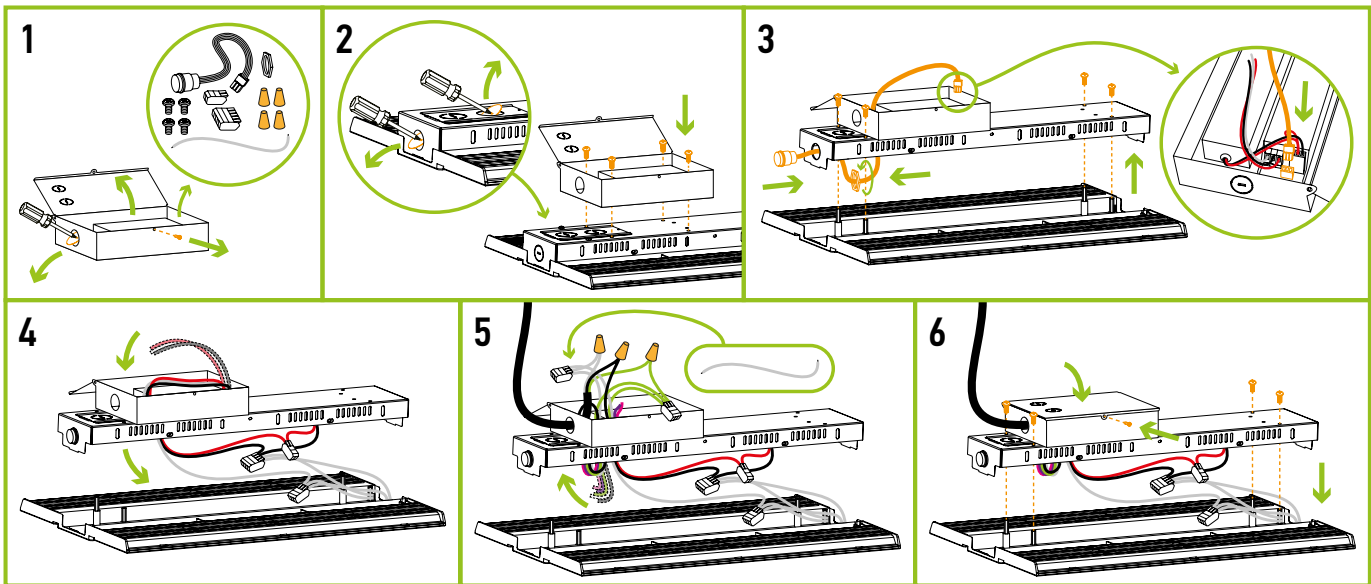
 For most up-to-date spec sheets please refer to asd-lighting.com

ASD LIGHTING CORP

 E-mail: orders@asd-lighting.com | Web site: www.asd-lighting.com



LED LINEAR HIGH BAY WITH Q-BASE

INSTALLATION GUIDE

IMPORTANT SAFETY INFORMATION:

Please read all the instructions below before installation.

- ▶ Make sure that the supply voltage corresponds to the rated product voltage.
- ▶ The product must be installed by a qualified electrician in accordance with the National Electrical Code and corresponding local codes.
- ▶ If the product is damaged, do not use it.

⚠ WARNING

RISK OF PERSONAL INJURY – READ and follow all WARNINGS and installation instructions. Keep or give to the owner for future reference.

Risk of cuts: Wear gloves to prevent cuts or abrasions when removing from carton, handling, installing, and maintaining this product.

Risk of electric shock: This product must be installed in accordance with the applicable installation code by a person familiar with the construction and operation of the product and the hazards involved.

Risk of Fire: Minimum 194°F supply conductors. Consult a qualified electrician to ensure correct branch circuit conductor.

ASD® assumes no responsibility for claims arising out of improper or careless installation or handling of this product.

ELECTRICAL SCHEMATIC DIAGRAM:

WHB5A (100/160/220/320W)

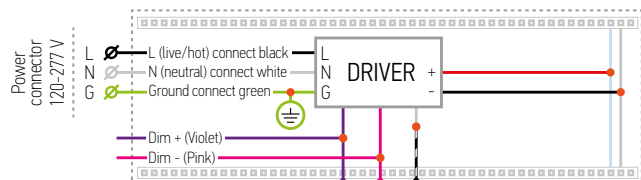

WHB5A multiple fixture connection

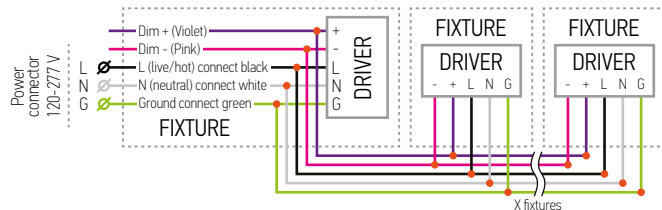

WHB5A with motion sensor and battery back-up kit (100/160/220/320W)

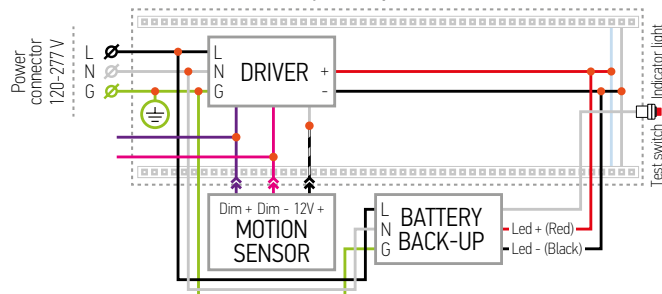

WHB5A (400/500W)

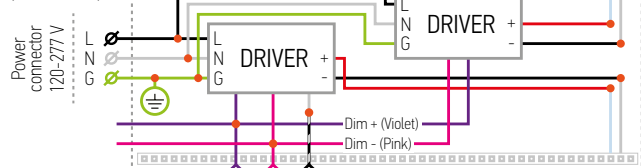

WHB5A with motion sensor and battery back-up kit (400/500W)

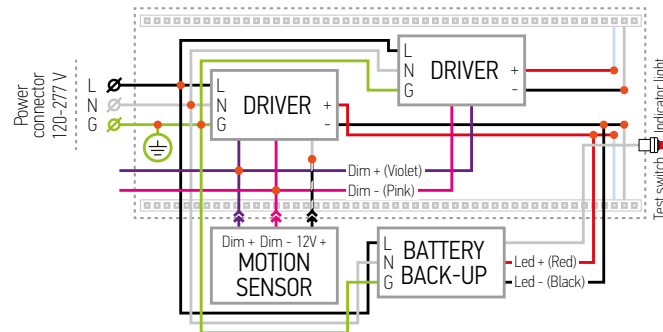

WHB5A-PRO (100/160/220/320W)

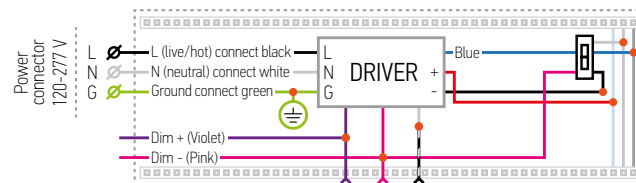

WHB5A-PRO with motion sensor and battery back-up kit (100/160/220/320W)

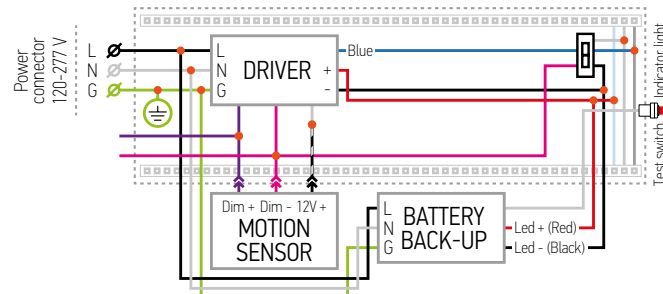

WHB5A-PRO (500W)

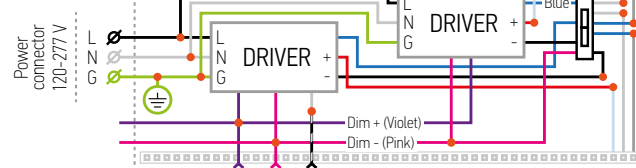

WHB5A-PRO with motion sensor and battery back-up kit (500W)

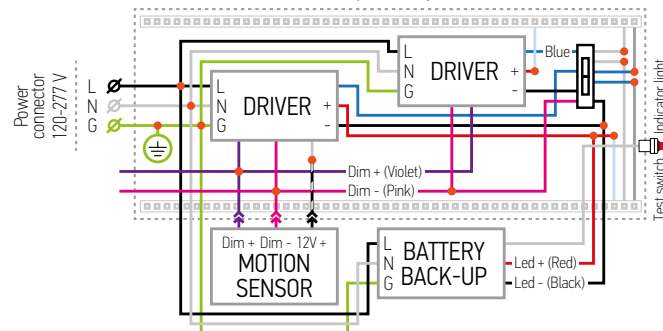

For most up-to-date spec sheets please refer to asd-lighting.com



LED LINEAR HIGH BAY WITH Q-BASE

WHB5A-HV-PRO (220/320W)

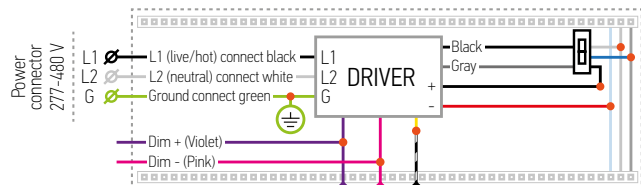

WHB5A-HV-PRO with motion sensor (220/320W)

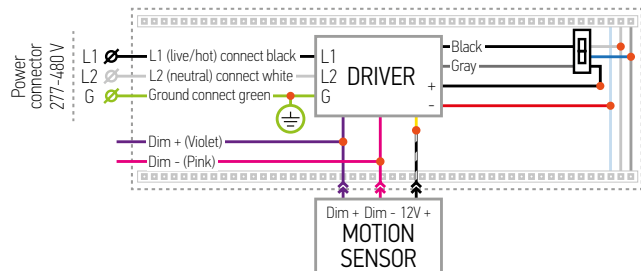

WHB5A-HV-PRO (500W)

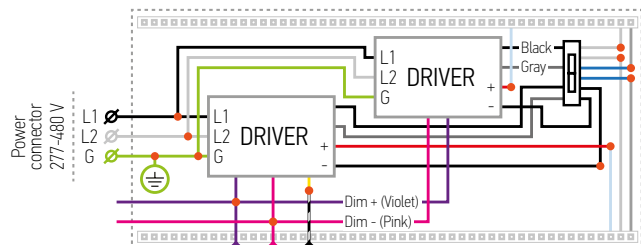

WHB5A-HV-PRO with motion sensor (500W)

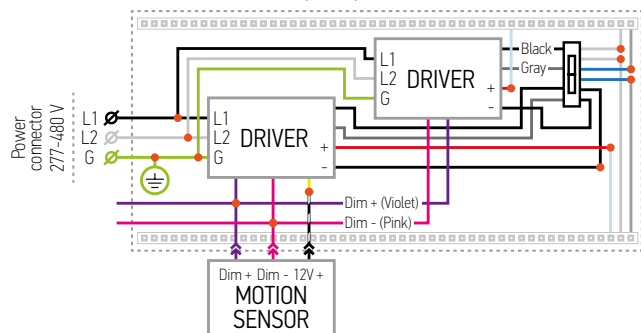

WHB5A with battery back-up

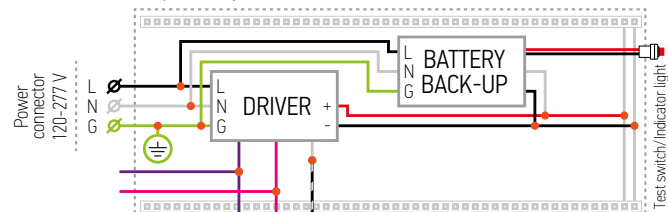

WHB5A with motion sensor and battery back-up

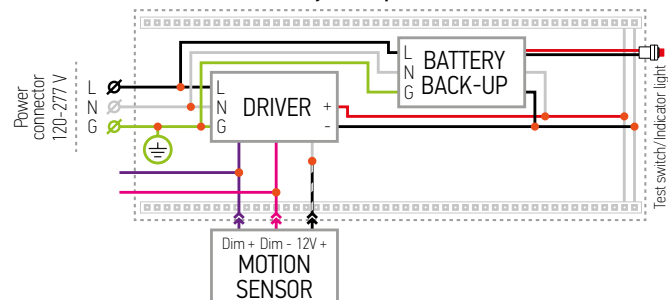

WHB5A-PRO with battery back-up

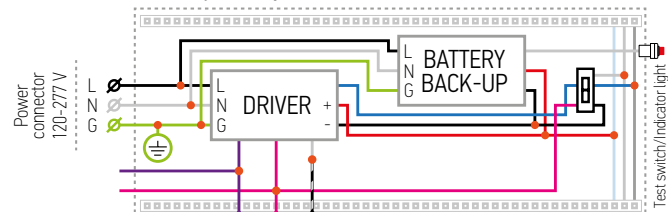

WHB5A-PRO with motion sensor and battery back-up

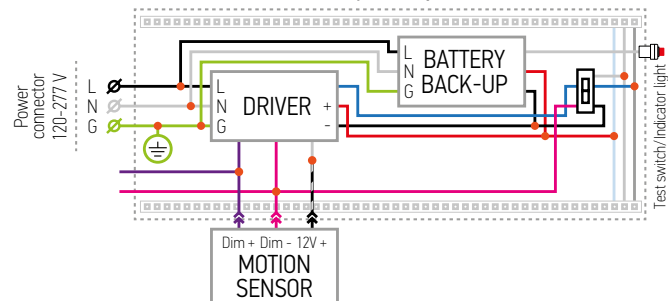

For most up-to-date spec sheets please refer to asd-lighting.com



LED LINEAR HIGH BAY WITH Q-BASE

CHAIN MOUNT:

1. Insert V-hooks into both ends of the fixture. Secure chain to ceiling, beam or other mounting surface.
2. Unscrew and open backplate, use screwdriver to open one knockout.
3. Connect the wires: Black to Black, White to White, Green to Green. If you are not using the dimming wires cap them off but not together. Reattach knockout plate to top of the fixture and secure with screw.

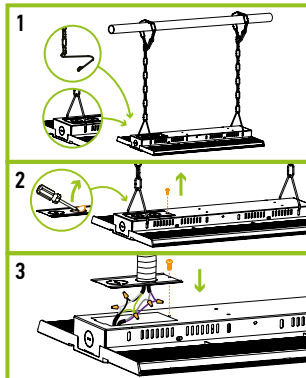

WIRE GUARD

ASD-WG14-WHB5

ASD-WG20-WHB5

sold separately:

1. Slide the wire guard from the side to the bottom.
2. Secure the wire guard with screws on both sides.

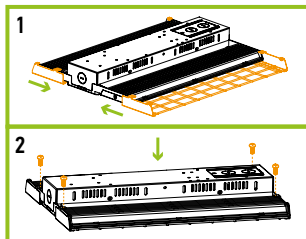

SURFACE MOUNT

ASD-SMB1-WHB5

sold separately:

1. Secure the brackets to ceiling, beam, joist or rail. (bolts not included).
2. Connect the wires: Black to Black, White to White, Green to Green.
3. Attach the fixture to the bracket and secure with one screw per each side of the bracket.

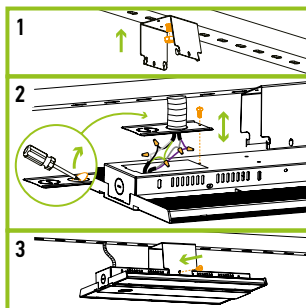

PENDANT MOUNT

ASD-PMB1-WHB5

ASD-PMB2-WHB5

sold separately:

1. Assemble metal hose with connectors and attach bracket's side plate to one side. Install the bracket on 3/4" NPT pipe. Bracket does not include nuts or screws for mounting to surface.
2. Unscrew and take off fixture's backplate, open one knockout using screwdriver. Then attach backplate to free end of the metal hose. Attach the bracket by putting the bracket's hooks into the slots in the center of the housing. Secure the bracket with screws. Connect the wires: Black to Black, White to White, Green to Green.
3. Reattach the backplate in its place and secure with screw. Align the studs of the side plate with the slots in the housing, place the side plates, and secure them with screws.

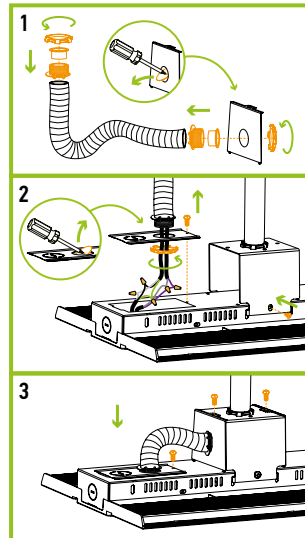

MOTION SENSOR

HD09VR-MH

HD09VR-PH

sold separately:

1. Unscrew the microwave sensor base cap.
2. Insert and twist the sensor until it is tight on the base surface.

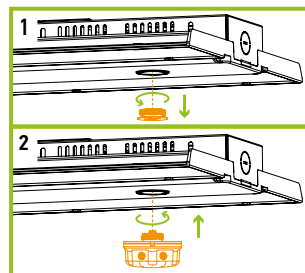

POWER AND COLOR TEMPERATURE SETTINGS:

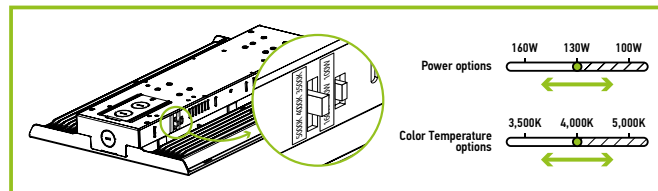

For most up-to-date spec sheets please refer to asd-lighting.com



LED LINEAR HIGH BAY WITH Q-BASE

ORDERING INFORMATION

Model	UPC	Pcs. per carton	Carton size	Carton weight	GTIN 14
WHB5A					
ASD-WHB5A-100D50	810050738705	1	14.8" x 10.6" x 2.4"	5 lbs	-
ASD-WHB5A-160D50	810050738712	1	14.8" x 10.6" x 2.4"	5 lbs	-
ASD-WHB5A-A160DAC	810050739870	1	14.8" x 10.6" x 2.4"	5.1 lbs	-
ASD-WHB5A-220D50	810050738729	1	20.3" x 12.6" x 3"	7.6 lbs	-
ASD-WHB5A-320D50	810050738736	1	40" x 12.6" x 3"	14.9 lbs	-
ASD-WHB5A-A320DAC	810128111072	1	40" x 12.6" x 3"	15.2 lbs	-
ASD-WHB5A-400D50	810050738743	1	40" x 12.6" x 3"	14.9 lbs	-
ASD-WHB5A-500D50	810050739863	1	40" x 12.6" x 3"	15.2 lbs	-
ASD-WHB5A-A500DAC	810128111089	1	40" x 12.6" x 3"	16.3 lbs	-
WHB5A-PRO					
ASD-WHB5A-PRO-100	810128111065	1	14.8" x 10.6" x 2.4"	5.3 lbs	-
ASD-WHB5A-PRO-160	810128113656	1	20.3" x 12.6" x 3"	7.7 lbs	-
ASD-WHB5A-PRO-220	810128110648	1	20.3" x 12.6" x 3"	7.9 lbs	-
ASD-WHB5A-PRO-320	810128113663	1	40" x 12.6" x 3"	14.8 lbs	-
ASD-WHB5A-PRO-500	810128113670	1	40" x 12.6" x 3"	15.2 lbs	-
WHB5A-HV-PRO HIGH VOLTAGE					
ASD-WHB5A-HV-PRO-220	810128113625	1	20.3" x 12.6" x 3"	7.9 lbs	-
ASD-WHB5A-HV-PRO-320	810128113632	1	40" x 12.6" x 3"	14.8 lbs	-
ASD-WHB5A-HV-PRO-500	810128113649	1	40" x 12.6" x 3"	15.2 lbs	-
WHB5A-EM WITH BATTERY BACK-UP					
ASD-WHB5A-160D50-20EM	819201020799	1	14.8" x 10.6" x 3.4"	6.3 lbs	-
ASD-WHB5A-A160DAC-20EM	810128111805	1	14.8" x 10.6" x 3.4"	6.4 lbs	-
ASD-WHB5A-220D50-20EM	810050739894	1	20.3" x 12.6" x 3"	8.8 lbs	-
ASD-WHB5A-A220DAC-20EM	810128111812	1	20.3" x 12.6" x 3"	9 lbs	-
WHB5A-PRO-EM WITH BATTERY BACK-UP					
ASD-WHB5A-PRO-160-EM	810128113205	1	20.3" x 12.6" x 3"	9 lbs	-
ASD-WHB5A-PRO-220-EM	810128113212	1	20.3" x 12.6" x 3"	9.3 lbs	-
HD09VR-MH	810128112284	120	15.8" x 11.8" x 9.3"	13.2 lbs	10810128112281
HD09VR-PH	810128112277	120	15.8" x 11.8" x 9.3"	13.2 lbs	10810128112274
HD05R	810050738767	78	15.8" x 11.8" x 9.3"	21.5 lbs	10810050738764

ACCESSORIES:

Model	Description	UPC	Pcs. per carton	Carton size	Carton weight	GTIN 14
ASD-EMK20W-WHB5A	Battery back-up kit 20W	810050737333	10	10.5" x 10.2" x 11.5"	26.5 lbs	10810050737330
ASD-EMK20W-WHB5B	Battery back-up kit 20W	810128113977	10	10.5" x 10.2" x 11.5"	26.5 lbs	10810128113974
ASD-EMK30W-WHB5A	Battery back-up kit 30W	810050735933	10	10.5" x 10.2" x 11.5"	26.5 lbs	10810050735930
ASD-SMB1-WHB5	Surface mount bracket	810050739764	50	22.8" x 7.9" x 20.9"	24.3 lbs	20810050739768
ASD-PMB1-WHB5	Pendant mounting bracket for 100/160/220W	810050739757	50	22.8" x 7.9" x 20.9"	34.2 lbs	20810050739751
ASD-PMB2-WHB5	Pendant mounting bracket for 320/400/500W	810050739771	50	22.8" x 7.9" x 20.9"	34.2 lbs	20810050739775
ASD-WG14-WHB5	Wire guard 14"	810050739733	50	15.8" x 14.6" x 14.6"	27.6 lbs	20810050739737
ASD-WG20-WHB5	Wire guard 20"	810050739740	50	21.1" x 20.9" x 11.4"	39.7 lbs	20810050739744

For most up-to-date spec sheets please refer to asd-lighting.com