



LED SOLID LENS LINEAR HIGH BAY

► **DESIGN & OPTIONS** - LED SOLID LENS LINEAR HIGH BAY has durable housing and energy-efficient LED drivers to ensure high performance. The PC frosted lens is impact-resistant and extremely tough, while the housing is designed to maximize heat dissipation. They come equipped with 1-10V dimmable. These fixtures run on 120-277V circuits, and come in a 5,000K color temperature with a WHITE finish.



Models with a built-in microwave motion sensor automatically turn off in the absence of motion and can be programmed via wireless remote.



The battery back-up kit provides 90 minutes of power in case of emergency.

► **INSTALLATION** - These fixtures have three different mounting options: suspended, surface, and pendant. They can easily be suspended using the included chains and V-hook. Surface and pendant mount brackets are also available (sold separately). Refer to install instructions for detailed steps.

► **APPLICATION** - LED SOLID LENS LINEAR HIGH BAY are the perfect commercial or industrial solution for warehouses, supermarkets, retail stores, gyms, garages, general task areas, and many other applications. This fixture is also Damp Location rated and can operate in temperatures ranging from -22 to 122°F (-30 to 50°C), allowing it to be utilized in a wide variety of applications and climates.

► **ENERGY SAVINGS & EFFICIENCY** - With a calculated lifespan up to 173,000 hours, these fixtures are made to last decades under normal operation! This fixture can cut your electric bill by up to 80% instantly and will save you a significant amount of money in its lifetime.

► **CERTIFICATION & WARRANTY** - Buy with confidence: ASD provides a 5-year limited warranty along with UL certification to guarantee top quality products and safety!

DLC Premium classification allows participation in rebates; please check the rebate programs available in your state.

Catalog number	
Notes	
Type	



Model	Size	Watts	Voltage	Dimmable	Lumens	CCT	Dimensions (LxWxH)	Option	
ASD-WHB7-2D11050	2 ft	110W	120-277V	0-10 V	14,960 lm	5,000 K	24" x 12-9/16" x 3"	-	
ASD-WHB7-2D16550	2 ft	165W	120-277V	0-10 V	22,440 lm	5,000 K	24" x 12-9/16" x 3"	-	
ASD-WHB7-2D22050	2 ft	220W	120-277V	0-10 V	29,700 lm	5,000 K	24" x 12-9/16" x 3"	-	
ASD-WHB7-4D22050	4 ft	220W	120-277V	0-10 V	29,920 lm	5,000 K	46-1/16" x 12-9/16" x 3"	-	
WHB7-MSR WITH MOTION SENSOR									
ASD-WHB7-2D11050-MSR	2 ft	110W	120-277V	0-10 V	14,960 lm	5,000 K	24" x 12-9/16" x 3"	Motion sensor	
ASD-WHB7-2D16550-MSR	2 ft	165W	120-277V	0-10 V	22,440 lm	5,000 K	24" x 12-9/16" x 3"	Motion sensor	
ASD-WHB7-2D22050-MSR	2 ft	220W	120-277V	0-10 V	29,700 lm	5,000 K	24" x 12-9/16" x 3"	Motion sensor	
ASD-WHB7-4D22050-MSR	4 ft	220W	120-277V	0-10 V	29,920 lm	5,000 K	46-1/16" x 12-9/16" x 3"	Motion sensor	
UHB-RC-MSK1	Remote controller for motion sensor							4-1/2" x 2-1/8" x 1/2"	-

ORDERING INFORMATION

Model	UPC	Pcs. per carton	Carton size	Carton weight	GTIN 14
ASD-WHB7-2D11050	810050735346	1	26.7" x 15.1" x 5.6"	10.8 lb	-
ASD-WHB7-2D16550	810050735353	1	26.7" x 15.1" x 5.6"	11.7 lb	-
ASD-WHB7-2D22050	810050735360	1	26.7" x 15.1" x 5.6"	11.7 lb	-
ASD-WHB7-4D22050	810050736930	1	49.6" x 15.1" x 5.6"	19 lb	-
WHB7-MSR WITH MOTION SENSOR					
ASD-WHB7-2D11050-MSR	810050736176	1	26.7" x 15.1" x 5.6"	11 lb	-
ASD-WHB7-2D16550-MSR	810050736183	1	26.7" x 15.1" x 5.6"	11.9 lb	-
ASD-WHB7-2D22050-MSR	810050736190	1	26.7" x 15.1" x 5.6"	11.9 lb	-
ASD-WHB7-4D22050-MSR	810050736206	1	49.6" x 15.1" x 5.6"	19.2 lb	-
UHB-RC-MSK1	819201022007	100	14.6" x 12.8" x 12.2"	11.3 lb	10819201022004

ACCESSORIES:

Model	Name	UPC	Pcs. per carton	Carton size	Carton weight	GTIN 14
ASD-SMB-WHB5-110/220W	Surface Mounting Bracket for 110/220W	819201024902	20	18.9" x 7.8" x 7.9"	21.3 lb	10819201024909
ASD-PMB-WHB5-110/220W	Pendant Mounting Bracket for 110/220W	819201024919	20	17.4" x 8" x 7.8"	12.9 lb	10819201024916
ASD-EMK20W-WHB5M	Battery back-up kit 20W	810050734974	10	10.6" x 10.6" x 10.6"	28.7 lb	10810050734971

For most up-to-date spec sheets please refer to asd-lighting.com

ASD LIGHTING CORP

E-mail: orders@asd-lighting.com | Web site: www.asd-lighting.com





LED SOLID LENS LINEAR HIGH BAY

PRODUCT SPECIFICATIONS:

Construction & Materials					
Housing	Steel				
Lens	PC				
Finish	White				
Weight	ASD-WHB7-2D11050	9 lb (4.1 kg)	ASD-WHB7-2D11050-MSR	9.3lb (4.2 kg)	
	ASD-WHB7-2D16550	9.9 lb (4.5 kg)	ASD-WHB7-2D16550-MSR	10.1lb (4.6 kg)	
	ASD-WHB7-2D22050		ASD-WHB7-2D22050-MSR		
	ASD-WHB7-4D22050	15.7lb (7.1 kg)	ASD-WHB7-4D22050-MSR	15.9lb (7.2 kg)	
Environmental system					
Work environment	Suitable for Damp Locations, IP40				
Operating temperature	-22°F to 122°F (-30°C to 50°C)				
L-70 Life	R > 54,000 hrs; C > 173,000 hrs				
Optical system					
Luminous flux	ASD-WHB7-2D11050	14,960 lm	ASD-WHB7-2D11050-MSR	14,960 lm	
	ASD-WHB7-2D16550	22,440 lm	ASD-WHB7-2D16550-MSR	22,440 lm	
	ASD-WHB7-2D22050	29,700 lm	ASD-WHB7-2D22050-MSR	29,700 lm	
	ASD-WHB7-4D22050	29,920 lm	ASD-WHB7-4D22050-MSR	29,920 lm	
Color temperature	5,000 K				
CRI	> 80				
Electrical system					
Input voltage	120-277 V				
Max input current	ASD-WHB7-2D11050	1.1 A	ASD-WHB7-2D11050-MSR	1.1 A	
	ASD-WHB7-2D16550	1.5 A	ASD-WHB7-2D16550-MSR	1.5 A	
	ASD-WHB7-2D22050	2.1 A	ASD-WHB7-2D22050-MSR	2.1 A	
	ASD-WHB7-4D22050		ASD-WHB7-4D22050-MSR		
Inrush current (Action time)	110 A (< 1 S)		for models 110W: 60 A (< 1 S)		
AC input range	for WHB7: min 100 V max 305 V		for WHB7-MSR: min 108 V max 305 V		
Off state power	0W				
Power consumption	ASD-WHB7-2D11050	110W	ASD-WHB7-2D11050-MSR	110W	
	ASD-WHB7-2D16550	165W	ASD-WHB7-2D16550-MSR	165W	
	ASD-WHB7-2D22050	220W	ASD-WHB7-2D22050-MSR	220W	
	ASD-WHB7-4D22050		ASD-WHB7-4D22050-MSR		
Power factor	> 0.9				
Output voltage	90-130 V				
Max output current	ASD-WHB7-2D11050	820 mA	ASD-WHB7-2D11050-MSR	820 mA	
	ASD-WHB7-2D16550	600 mA * 2	ASD-WHB7-2D16550-MSR	600 mA * 2	
	ASD-WHB7-2D22050	820 mA * 2	ASD-WHB7-2D22050-MSR	820 mA * 2	
	ASD-WHB7-4D22050		ASD-WHB7-4D22050-MSR		
Surge protection DM/CM	4 kV / 6 kV				
LED driver class	Non-Isolated, Class P				
Dimming compatible controls *					
Brand	Maxxima	Eaton	Keygma	Leviton	Lutron
Models	MEW-DM600LV	DF10P-C1	KGM-1A010V	IP710-DLZ	DVSTV-WH

Regular and voluntary certifications	
5-year limited warranty	
DesignLights Consortium (DLC) listed (Classification: Premium)	
Main: Indoor Luminaires;	
General Application: High-Bay;	
Primary Use: High-Bay Luminaires for Commercial and Industrial Buildings	
UL certified E473804	

* The list of dimmers is relevant for models without a motion sensor.

PACKAGE CONTENTS:

Description	Q-ty
LED Solid Lens Linear High Bay	1
Hanging kit: V hook, Chain 3.2ft (A)	1
Box	1

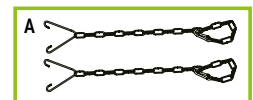

For most up-to-date spec sheets please refer to asd-lighting.com



LED SOLID LENS LINEAR HIGH BAY

ACCESSORIES (sold separately):

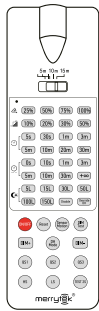
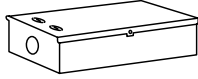
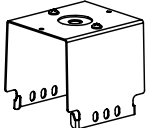
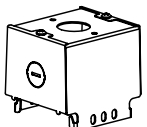
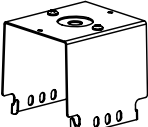
Remote controller for motion sensor UHB-RC-MSK1 	Battery back-up kit 20W ASD-EMK20W-WHB5M 	Surface mount bracket ASD-SMB-WHB5-110/220W 
	Pendant mounting bracket ASD-PMB-WHB5-110/220W 	

ACCESSORY COMPATIBILITY LIST:

Accessories	Remote controller for motion sensor UHB-RC-MSK1	Battery back-up kit 20W ASD-EMK20W-WHB5M	Surface mount bracket ASD-SMB-WHB5-110/220W	Pendant mounting bracket ASD-PMB-WHB5-110/220W
Models				
ASD-WHB7-2D11050		•	•	•
ASD-WHB7-2D16550		•	•	•
ASD-WHB7-2D22050		•	•	•
ASD-WHB7-4D22050		•	•	•
ASD-WHB7-2D11050-MSR	•	•	•	•
ASD-WHB7-2D16550-MSR	•	•	•	•
ASD-WHB7-2D22050-MSR	•	•	•	•
ASD-WHB7-4D22050-MSR	•	•	•	•

BUILT-IN MOTION SENSOR INFORMATION

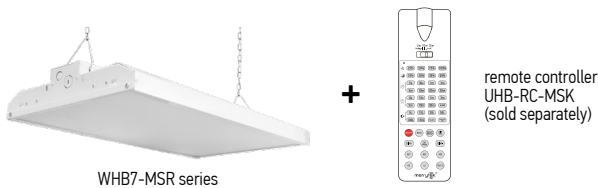

- ▶ Sensor parameters can be conveniently set via remote control (sold separately)
- ▶ Mounting height up to 49.2ft (15m) max., suitable for warehouse use
- ▶ Built-in adjustable daylight sensor

Specifications	Model MC079D RC2B
Operating voltage	12 Vdc ± 1 V
Operating current	25 mA
Working mode	0-10 V DC
Detection area	25 %/50 %/75 %/100 %
Hold time	5 s/1 min/3 min/5 min/10 min/20 min/30 min
Daylight threshold	5 Lx (0.5 Fc)/15 Lx (1.4 Fc)/30 Lx (2.8 Fc)/50 Lx (4.7 Fc)/100 Lx (9.3 Fc)/150 Lx (14 Fc)/Disable
Standby period	0 s/10 s/1 min/3 min/5 min/10 min/30 min/+ ∞
Standby dimming level	10 %/20 %/30 %/50 %
Operating Frequency	5.8 GHz ± 75 MHz, ISM band.
Transmitting power	1mW max
Stand-by power	< 0.3 mW
Mounting height	Max.15 m/49.2 ft
Detection range	Max.12 m/39.37 ft

DEFAULT SETTING:

Detection area	Hold time	Daylight sensor	Stand-by period	Stand-by dim level	Sensitivity
100 %	20 min	Disable	0 s	10 %	Low (LS)

⚠ RF interference may affect the operation of this sensor.

Coverage area for ceiling mounting:

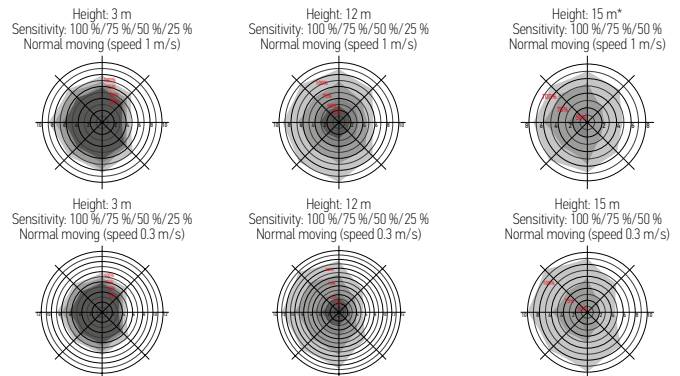

* Only 100 %/75 %/50 % detection sensitivity is workable when installed at 15 m mounting height 25 % sensitivity is not able to detect motion signal.

Coverage area for wall mounting:

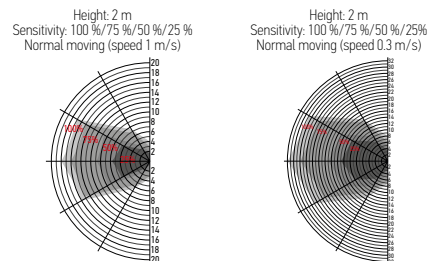

For most up-to-date spec sheets please refer to asd-lighting.com



LED SOLID LENS LINEAR HIGH BAY

REMOTE CONTROL **UHB-RC-MSK1** sold separately:

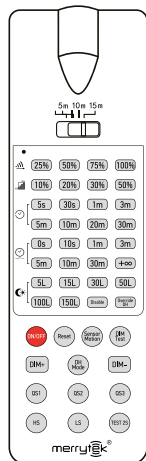

Button	Remarks
ON/OFF	Press the "ON/OFF" button: the fixture will switch to the constant on/off mode. Use ON/OFF button to on and off the fixture. Press any another button to switch back to the motion sensor mode.
Reset	Press "Reset" button: all parameters are the same as the DIP switch or factory settings.
Sensor motion	Press "Sensor motion" button, the light quits from the constant on/off mode, and the sensor starts to work (The latest setting stays in validity).
Dim test	Press "Dim test" button: the 0-10 V dimming works to test whether the 0-10 V dc dimming parts are connected properly. After 2 s, it returns to the latest setting automatically.
Override DH	Hold for 3 s: daylight priority mode will be switched to daylight threshold mode with the preset daylight value.
DIM + DIM -	Set occupancy light level in range of 50 % - 100 %. Dim level changes by 2 % each time Dim + / Dim - is pressed.
DH Mode	Hold for 3 s: sensor will be switched to daylight priority mode, if the preset daylight value is set to "Disable" the sensor will stay in daylight threshold mode.
Escena opcio	Detection area Hold time Standby period Standby dim level Daylight sensor Induction model
QS1	100 % 5 min 10 min 10 % 30 Lx (2.8 Fc) HS
QS2	100 % 10 min 30 min 10 % Disable HS
QS3	100 % 20 min 30 min 10 % Disable HS
Test 2 s	Press the "Test 2 s" button at any time to enter test mode. In this mode the sensor parameters are as follows: Detection area is 100 %, Hold time is 5 s, Standby dim level is 10 %, Standby period is 0 s, daylight sensor is disabled. This function is only for testing. Press "Reset" or any other function button to exit this mode.
HS LS	Press the "HS" button for high sensitivity in the detection area. Press the "LS" button for low sensitivity in the detection area. The adjustment is based on the "Detection area" parameter you set.
Daylight sensor	Set up daylight threshold: 5 Lx (0.5 Fc) / 15 Lx (1.4 Fc) / 30 Lx (2.8 Fc) / 50 Lx (4.7 Fc) / 100 Lx (9.3 Fc) / 150 Lx (14 Fc) / Disable
Standby dim level	Set up standby dim level: 10 % / 20 % / 30 % / 50 %
Standby period	Set up standby time: 0 s / 10 s / 1 min / 3 min / 5 min / 10 min / 30 min / + ∞
Detection area	Set up detection area: 25 % / 50 % / 75 % / 100 %
Hold time	Set up hold-time: 5 s / 30 s / 1 min / 3 min / 5 min / 10 min / 20 min / 30 min
Remote distance	Toggle the button to set the remote distance of remote control and sensor.

Remote control and code setting conversion:

1. DIP switch settings convert to remote control: Press any button except "Reset" on the remote control, and the sensor settings convert to the function currently selected by the remote control. (No function button settings invalid).

2. Remote control convert to DIP switch settings:

a. Press the "Reset" button on the remote control, and all settings return to the DIP switch settings of the sensor.

b. Turn off the power, toggle any DIP switch, connect to the power, and all settings return to the DIP switch settings when power is supplied again.

To manually set your fixture use the top set of buttons on your wireless remote control. There are 5 sets of parameters to set.

Detection area – sensitivity of motion sensor in percent.

Hold time – time the fixture will remain at full brightness after no motion is detected.

Stand by time – time fixture will remain on at a reduced brightness.

Stand by dim level – light output level after hold time expires and stand by time starts.

Daylight threshold – fixture can be set to adjust light output based on ambient light levels in the area.

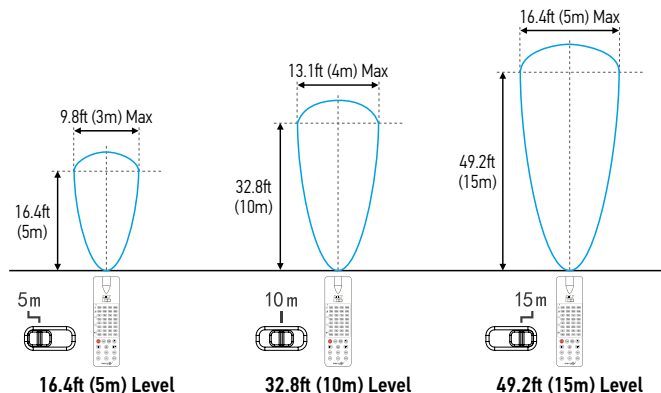

2-STEP DIMMING FUNCTION (STAND BY PERIOD BE SET TO "+ ∞")

1. If there is no motion detected, the light will be remained at a low light level all the time.

2. When motion is detected, the sensor will switch on the light to 100% brightness.

3. After elapse of hold time, the sensor dims the light at the present low light level if no motion is detected.

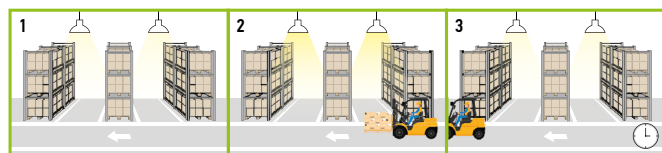

DAYLIGHT PRIORITY (STAND BY PERIOD SET TO "+ ∞")

1. Lamp turns on at 10% at night.

2. When motion is detected, lamp automatically lights up to 100%.

3. After hold time, the lamp gradually dims to 10% if no movement is detected.

4. Lamp turns off after dawn.

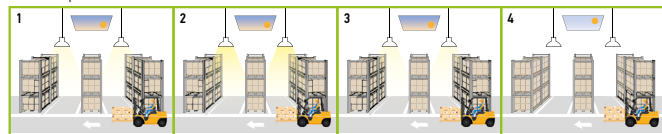

3-STEP DIMMING FUNCTION (STAND BY PERIOD BE SET TO "10 S/1 MIN/3 MIN/5 MIN/10 MIN/30 MIN")

1. With sufficient ambient light, the light will not be switched on even with the motion sensor activated.

2. With insufficient ambient light, the sensor will switch on the light when motion is detected.

3. After elapse of hold time, the sensor will dim the light if no new motion is detected.

4. After elapse of stand by period, the sensor switches off the light if no motion is detected.

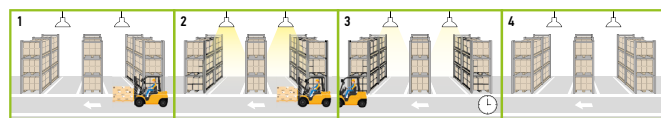

For most up-to-date spec sheets please refer to asd-lighting.com



LED SOLID LENS LINEAR HIGH BAY

To avoid blocking the microwave emission, the microwave sensor can not be covered with metal materials, be sprayed with a coating of metal components, or have attached metal material or stickers etc.

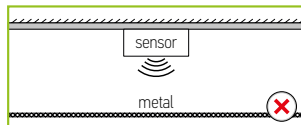

The distance between the antenna and the glass (dielectric material) should be no less than 13mm when the sensor is built in the glass lampshade. Otherwise, the microwave motion sensor will not penetrate the glass easily.

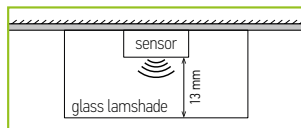

Avoid placing the sensor inside a metal chamber, this may cause a mis-trigger.

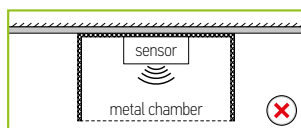

The sensor should not be placed in a small confined space. To avoid increasing the sensor detection range or abnormal operation, the sensor should be kept away from large areas of metal and glass reflectors (separation distance at least 1m). Reduce the detection area setting or contact Merrytek for more help.

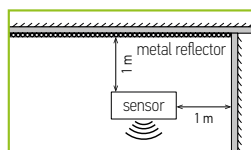

To avoid affecting the microwave signal transmission, the microwave antenna should be higher than the surrounding metal surface.

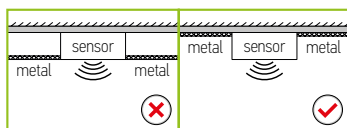

Any vibration or movement may trigger the sensor. Ensure the sensor is far from any constant movement.

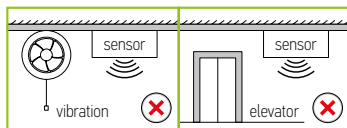

When multiple sensors are installed side-by-side in the same direction, the distance between each sensor should be kept at least 1m (the warehouse sensors at least 3m) to avoid mutual interference.

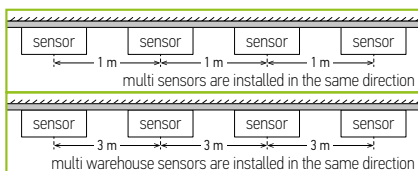

BACK-UP BATTERY KIT INFORMATION

ASD-EMK20W-WHB5M sold separately:

ASD-EMK20W-WHB5M self-check emergency battery back-up kit offers a dependable solution for virtually every LED Linear High Bay lighting application, with options tailored for both new fixture constructions and field installation applications. For more information please visit our website <https://www.asd-lighting.com/>

- ▶ Standard UL924 certification
- ▶ External LiFePO4 battery
- ▶ Battery Protection
- ▶ Over charge protection
- ▶ Over discharge protection
- ▶ Short circuit protection
- ▶ Battery Status Indicator Light
- ▶ Intelligent Emergency Detection Function
- ▶ 5 year warranty
- ▶ Emergency time : 90 minutes

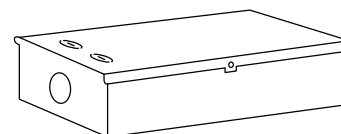

Emergency operation:

When the AC power goes out, the emergency driver detects the outage and automatically switches to the emergency mode. The red LED ON indicates that it is discharging, the red LED flashing indicates low battery power, and the red LED OFF indicates the discharge is complete.

Test button operation:

Press Test button to switch the system to emergency mode, release to get back to the AC mode. When in AC mode - the button light is red, when in Emergency mode - button light goes off.

Specifications	Model: ASD-EMK20W-WHB5M
Input voltage	120-277 V 50/60 Hz
AC input current	100 mA max.
AC input power rating	7.0W max.
Output current and voltage	170 mA 50 - 150 V DC
Output power	20W
Lumens	2,932 lm
Emergency time	≥ 1.5 Hours
Warranty	5 Years
Indicator light	Illuminated Test Switch, Red, Green, Yellow indicator Light
Battery	Li-ion battery - 11.1 V/4000 mAh
Battery charging current	250 mA
Charging time	≥ 24 Hours
Temperature rating (Ambient)	22°F to 122°F (30°C to +50°C)
Dimensions	9-5/8" x 4-9/16" x 1-7/8" (244 mm x 116 mm x 47 mm)
Weight	2.2 lb (1 kg)

For most up-to-date spec sheets please refer to asd-lighting.com



LED SOLID LENS LINEAR HIGH BAY

INSTALLATION GUIDE

IMPORTANT SAFETY INFORMATION:

Please read all the instructions below before installation.

- ▶ Make sure that the supply voltage corresponds to the rated product voltage.
- ▶ The product must be installed by a qualified electrician in accordance with the National Electrical Code and corresponding local codes.
- ▶ If the product is damaged, do not use it.

⚠ WARNING

RISK OF PERSONAL INJURY – READ and follow all WARNINGS and installation instructions. Keep or give to the owner for future reference.

Risk of cuts: Wear gloves to prevent cuts or abrasions when removing from carton, handling, installing, and maintaining this product.

Risk of electric shock: This product must be installed in accordance with the applicable installation code by a person familiar with the construction and operation of the product and the hazards involved.

Risk of Fire: Minimum 194°F supply conductors. Consult a qualified electrician to ensure correct branch circuit conductor.

ASD® assumes no responsibility for claims arising out of improper or careless installation or handling of this product.

ELECTRICAL SCHEMATIC DIAGRAM:

WHB7

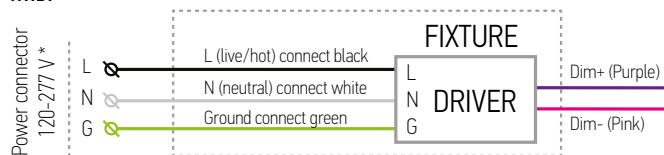

WHB7 with battery back-up kit (110W)

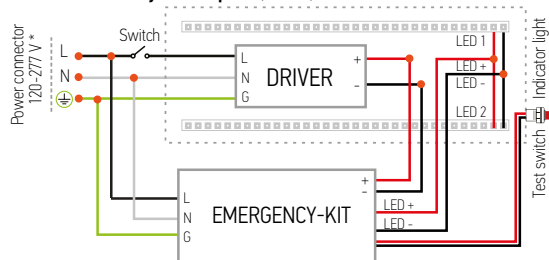

WHB7-MSR with motion sensor and battery back-up kit (110W)

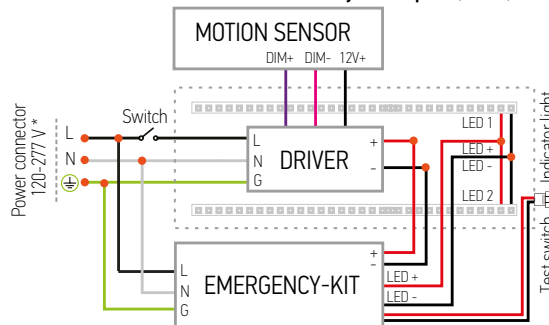

WHB7 multiple fixture connection

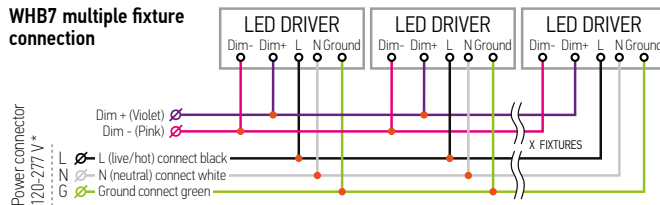

Recommended wire thickness should not exceed 18AWG.

WHB7-MSR with motion sensor

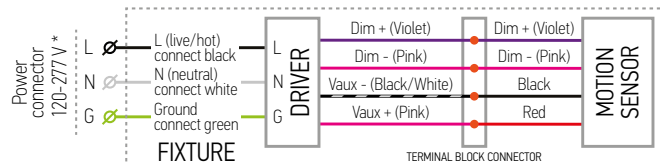

WHB7-MSR multiple fixture connection with motion sensor

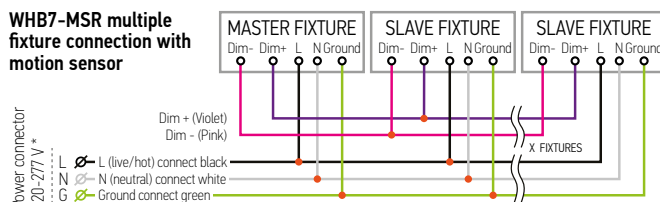

* The regular voltage 120-277 V fixtures can be alternatively powered without neutral by two-phase circuit with phase-to-phase voltage of 208 V (L1-120 V & L2-120 V).

WARNING: Phase-to-phase voltage should be less than 277 V (160 V per each phase) and more than 120V (70 V per each phase)! Do not confuse Regular Voltage fixtures of 120-277 V with High Voltage ones of 277-480 V!

WHB7 with battery back-up kit (165W, 220W)

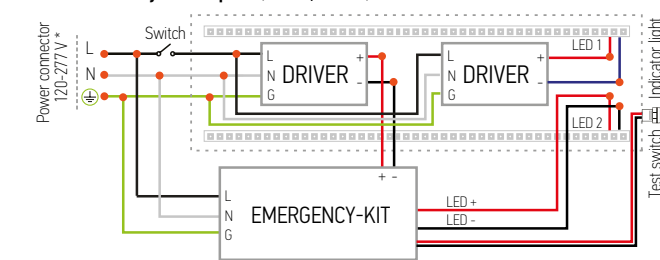

WHB7-MSR with motion sensor and battery back-up kit (165W, 220W)

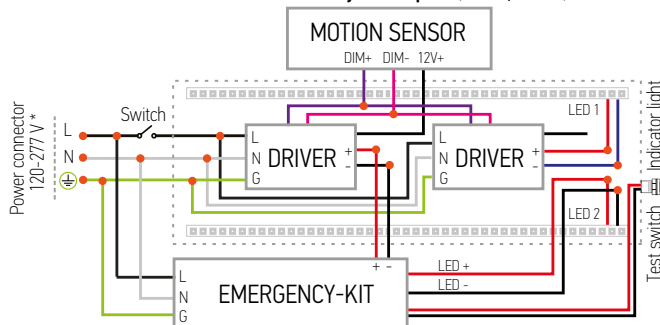

For most up-to-date spec sheets please refer to asd-lighting.com



LED SOLID LENS LINEAR HIGH BAY

INSTALLATION STEPS

CHAIN MOUNT:

1. Insert V-hooks into both ends of the fixture. Secure chain to ceiling, beam or other mounting surface. Use screwdriver to open the plate. Open the top knockout with a screwdriver. Screw the plate back on.
2. Connect the wires in accordance with the wiring diagram in these specifications. If you are not using the dimming wires cap them off but not together. Reattach knockout plate to top of the fixture.

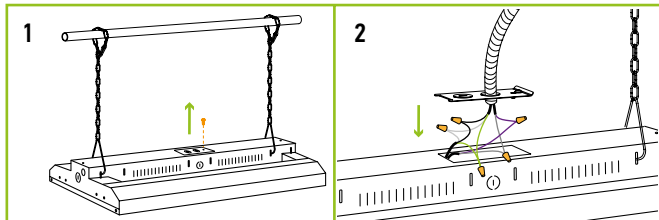

SURFACE MOUNT

ASD-SMB-WHB5-110/220W

sold separately:

1. Bolt the brackets to ceiling, beam, joist or rail. (bolts not included).
2. Connect the wires in accordance to the wiring diagram in these specifications. If you are not using the dimming wires cap them off but not together.
3. Attach the fixture to the bracket. Two screws per each side of the bracket.

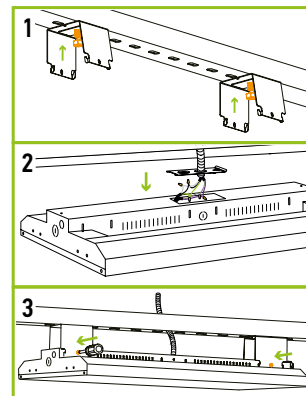

PENDANT MOUNT **ASD-PMB-WHB5-110/220W** sold separately:

1. Unscrew two bolts on the top of the bracket and remove side plates. Install the bracket on 3/4" NPT pipe. Bracket does not include nuts or screws for mounting to surface.
2. Attach the bracket by putting the bracket's hooks into the slots in the center of the housing. Fix the bracket with screws. Connect the wires following the wiring diagram. If you are not using the dimming wires cap them off but not together.
3. Align the studs of the side plate with the slots in the housing, set up the side plates, and fix them with screws.

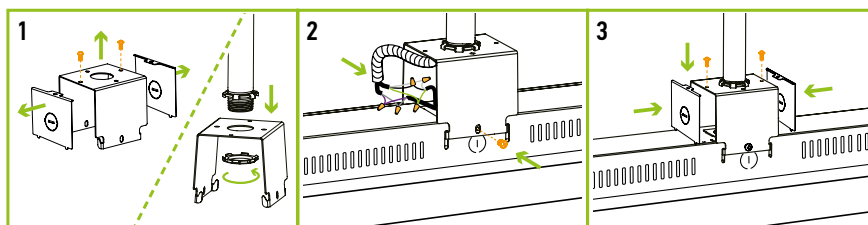

⚠ Caution: When Battery back-up kit is installed, pendant mount bracket cannot be used.

BATTERY BACK-UP KIT **ASD-EMK20W-WHB5M** sold separately:

1. Disassemble back plate of the fixture and open Emergency back-up box.
2. Pass the test button through the inside of the fixture and secure it in the knockout hole on the side of the fixture. Connect the wires: black to black, red to red, according to the wiring diagram.
3. Close Emergency back-up box, close back plate of the fixture and secure the Emergency box to the back plate of the fixture.

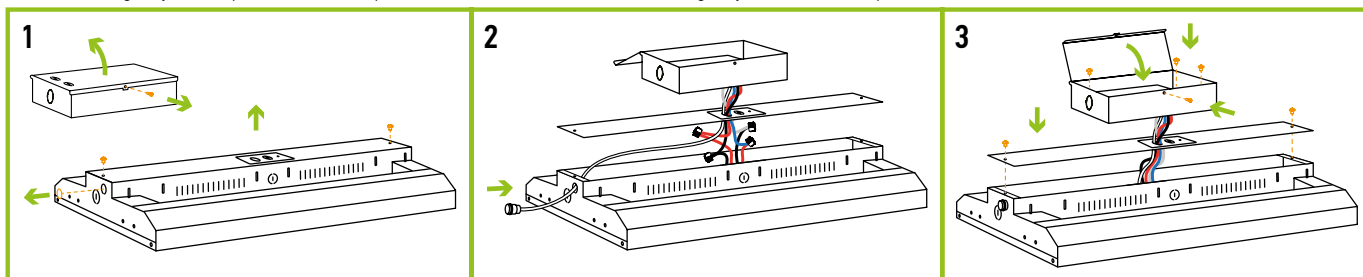

For most up-to-date spec sheets please refer to asd-lighting.com